

BXUV.U495 - Fire-resistance Ratings - ANSI/UL 263



Design/System/Construction/Assembly Usage Disclaimer

- Authorities Having Jurisdiction should be consulted in all cases as to the particular requirements covering the installation and use of UL Certified products, equipment, system, devices, and materials.
- Authorities Having Jurisdiction should be consulted before construction.
- Fire resistance assemblies and products are developed by the design submitter and have been investigated by UL for compliance with applicable requirements. The published information cannot always address every construction nuance encountered in the field.
- When field issues arise, it is recommended the first contact for assistance be the technical service staff provided by the product manufacturer noted for the design. Users of fire resistance assemblies are advised to consult the general Guide Information for each product category and each group of assemblies. The Guide Information includes specifics concerning alternate materials and alternate methods of construction.
- Only products which bear UL's Mark are considered Certified.

BXUV - Fire Resistance Ratings - ANSI/UL 263 Certified for United States

BXUV7 - Fire Resistance Ratings - CAN/ULC-S101 Certified for Canada

[See General Information for Fire-resistance Ratings - ANSI/UL 263 Certified for United States Design Criteria and Allowable Variances](#)

[See General Information for Fire Resistance Ratings - CAN/ULC-S101 Certified for Canada Design Criteria and Allowable Variances](#)

Design No. U495

December 31, 2020

Nonbearing Wall Rating — 1 or 2 Hr.

(See Items 5 and 7)

*** Indicates such products shall bear the UL or cUL Certification Mark for jurisdictions employing the UL or cUL Certification (such as Canada), respectively.**

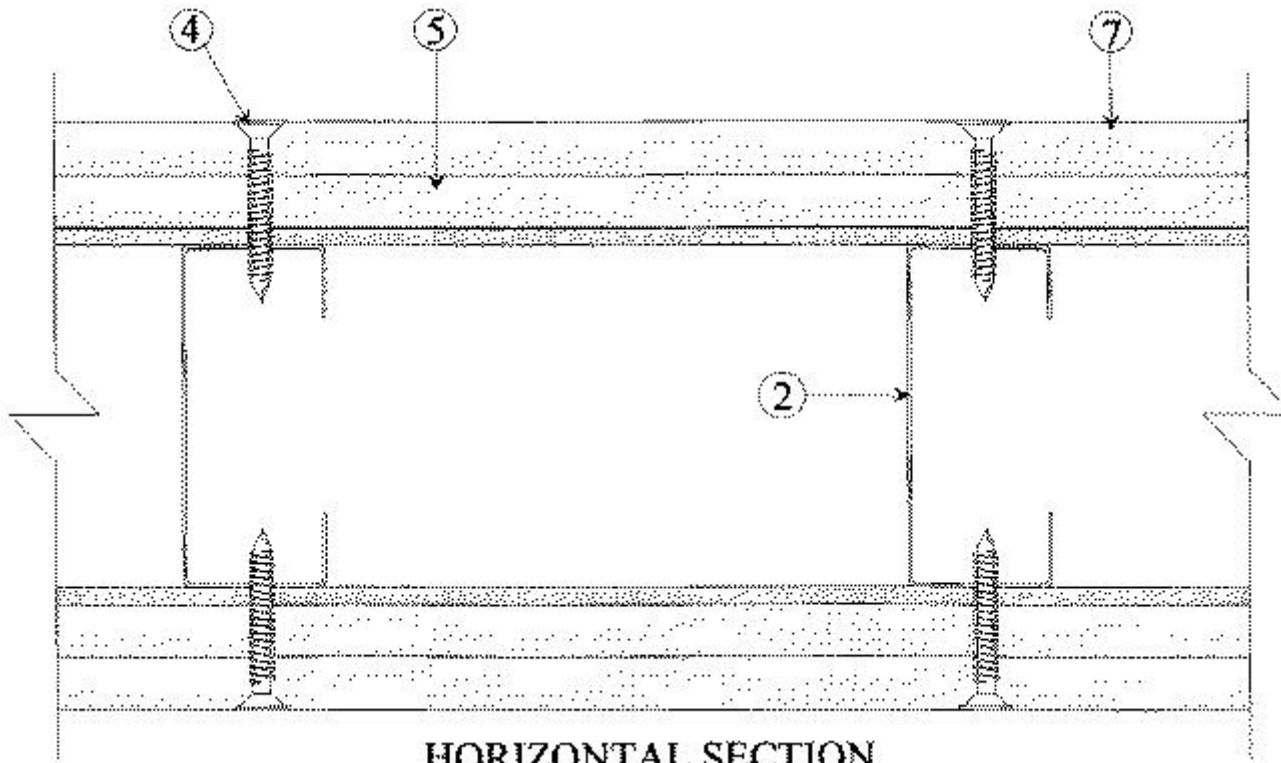

HORIZONTAL SECTION

1. Floor and Ceiling Runners — (Not Shown) — Channel-shaped runners, 3-5/8 in. wide (min), 1-1/4 in. legs, formed from No. 25 MSG (min) galv steel, attached to floor and ceiling with fasteners spaced 24 in. OC, max.

1A. Framing Members* — Floor and Ceiling Runners — Not Shown — In lieu of Item 1 — For use with Item 2A, proprietary channel shaped runners, 1-1/4 in. deep by min 3-5/8 in. wide fabricated from min 0.018 in. thick galv steel, attached to floor and ceiling with fasteners spaced 24 in. OC max.

CALIFORNIA EXPANDED METAL PRODUCTS CO — Viper20™ Track

MARINO/WARE, DIV OF WARE INDUSTRIES INC — Viper20™ Track

FUSION BUILDING PRODUCTS — Viper20™ Track

IMPERIAL MANUFACTURING GROUP INC — Viper20™ Track

1B. Framing Members* — Floor and Ceiling Runners — Not Shown — In lieu of Item 1 — For use with Item 2B, channel shaped runners, 1-1/4 in. deep by min 3-5/8 in. wide fabricated from min 0.018 in. thick galv steel, attached to floor and ceiling with fasteners spaced 24 in. OC max.

CLARKDIETRICH BUILDING SYSTEMS — CD ProTRAK

DMFCWBS L L C — ProTRAK

MBA METAL FRAMING — ProTRAK

RAM SALES L L C — Ram ProTRAK

STEEL STRUCTURAL PRODUCTS L L C — Tri-S ProTRAK

1C. Framing Members* – Floor and Ceiling Runners – Not Shown – In lieu of Item 1 – For use with Item 2C, proprietary channel shaped runners, 1-1/4 in. deep by min 3-5/8 in. wide fabricated from min 0.018 in. thick galv steel, attached to floor and ceiling with fasteners spaced 24 in. OC max.

MARINO/WARE, DIV OF WARE INDUSTRIES INC – Viper20™ Track

1D. Framing Members* – Floor and Ceiling Runners – Not Shown – In lieu of Item 1 – For use with Item 2D, channel shaped runners, 1-1/4 in. deep by min 3-5/8 in. wide fabricated from min 0.018 in. thick galv steel, attached to floor and ceiling with fasteners spaced 24 in. OC max.

TELLING INDUSTRIES L L C – TRUE-TRACK™

1E. Framing Members* – Floor and Ceiling Runners – Not Shown – In lieu of Item 1 – For use with Item 2F, channel shaped runners, 1-1/4 in. deep by min 3-5/8 in. wide fabricated from min 0.018 in. thick galv steel, attached to floor and ceiling with fasteners spaced 24 in. OC max.

RESCUE METAL FRAMING, L L C – AlphaTRAK

2. Steel Studs – Channel-shaped 3-5/8 in. wide (min), 1-1/4 in. legs, 3/8 in. folded back returns, formed from No. 25 MSG (min) galv steel, spaced 24 in. OC max.

2A. Framing Members* – Steel Studs – Not Shown – In lieu of Item 2 – For use with Item 1A, proprietary channel shaped steel studs, 1-1/4 in. deep by min 3-5/8 in. wide fabricated from min 0.018 in. thick galv steel. Studs cut 3/8 in. less in length than assembly height. Spaced 24 in. OC max.

CALIFORNIA EXPANDED METAL PRODUCTS CO – Viper20™

MARINO/WARE, DIV OF WARE INDUSTRIES INC – Viper20™

FUSION BUILDING PRODUCTS – Viper20™

IMPERIAL MANUFACTURING GROUP INC – Viper20™

2B. Framing Members* – Steel Studs – Not Shown – In lieu of Item 2 – For use with Item 1B, channel shaped steel studs, 1-1/4 in. deep by min 3-5/8 in. wide fabricated from min 0.018 in. thick galv steel. Studs cut 3/8 in. less in length than assembly height. Spaced 24 in. OC max.

CLARKDIETRICH BUILDING SYSTEMS – CD ProSTUD

DMFCWBS L L C – ProSTUD

MBA METAL FRAMING – ProSTUD

RAM SALES L L C – Ram ProSTUD

STEEL STRUCTURAL PRODUCTS L L C – Tri-S ProSTUD

2C. Framing Members* – Steel Studs – Not Shown – In lieu of Item 2 – For use with Item 1C, proprietary channel shaped steel studs, 1-1/4 in. deep by min 3-5/8 in. wide fabricated from min 0.018 in. thick galv steel. Studs cut 3/8 in. less in

length than assembly height. Spaced 24 in. OC max.

MARINO/WARE, DIV OF WARE INDUSTRIES INC – Viper20™

2D. Framing Members* – Steel Studs – Not Shown – In lieu of Item 2 – For use with Item 1D, channel shaped steel studs, 1-1/4 in. deep by min 3-5/8 in. wide fabricated from min 0.018 in. thick galv steel. Studs cut 3/8 in. less in length than assembly height. Spaced 24 in. OC max.

TELLING INDUSTRIES L L C – TRUE-STUD™

2E. Framing Members* – Steel Studs – As an alternate to Item 2 – For use with Item 1A (3-5/8 in. wide track), channel shaped studs, fabricated from min 25 MSG corrosion-protected steel, 1-1/4 in. wide by 3-5/8 in. deep, spaced a max of 24 in. OC. Studs to be cut 3/8 to 3/4 in. less than assembly height.

MARINO/WARE, DIV OF WARE INDUSTRIES INC – StudRite™

2F. Framing Members* – Steel Studs – Not Shown – In lieu of Item 2 – For use with Item 1E, channel shaped steel studs, 1-1/4 in. deep by min 3-5/8 in. wide fabricated from min 0.018 in. thick galv steel. Studs cut 3/8 in. less in length than assembly height. Spaced 24 in. OC max.

RESCUE METAL FRAMING, L L C – AlphaSTUD

3. Batts and Blankets* – (Optional, Not Shown) – Mineral wool or glass fiber batts partially or completely filling stud cavity. See **Batts and Blankets** (BZJZ) category for names of Classified companies.

3A. Fiber, Sprayed* – As an alternate to **Batts and Blankets** (Item 3) – (100% Borate Formulation) – Spray applied cellulose material. The fiber is applied with water to completely fill the enclosed cavity in accordance with the application instructions supplied with the product with a nominal dry density of 2.7 lb/ft³. Alternate Application Method: The fiber is applied without water or adhesive at a nominal dry density of 3.5 lb/ft³, in accordance with the application instructions supplied with the product.

U S GREENFIBER L L C – INS735, INS745 and INS750LD for use with wet or dry application. INS765LD and INS773LD are to be used for dry application only.

3B. Fiber, Sprayed* – As an alternate to **Batts and Blankets** (Item 3) - Spray applied cellulose insulation material. The fiber is applied with water to interior surfaces in accordance with the application instructions supplied with the product. Applied to completely fill the enclosed cavity. Minimum dry density of 4.3 pounds per cubic ft.

NU-WOOL CO INC – Cellulose Insulation

3C. Fiber, Sprayed* – As an alternate to Batts and Blankets (Item 3) – Spray applied cellulose fiber. The fiber is applied with water to completely fill the enclosed cavity in accordance with the application instructions supplied with the product. The minimum dry density shall be 4.30 lbs/ft³.

INTERNATIONAL CELLULOSE CORP – Celbar-RL

3D. Fiber, Sprayed* – As an alternate to Batts and Blankets (Item 3) – Spray applied cellulose material. The fiber is applied with water to completely fill the enclosed cavity in accordance with the application instructions supplied with the product. To facilitate the installation of the material, any thin, woven or non-woven netting may be attached by any means possible to the outer face the studs. The material shall reach equilibrium moisture content before the installation of materials on either face of the studs. The minimum dry density shall be 5.79 lbs/ft³.

APPLEGATE HOLDINGS L L C – Applegate Advanced Stabilized Cellulose Insulation

4. **Screws** — Type S self-tapping screws, 1-1/4 or 2 in. long, (1 Hr) and 2-1/2 in. long (2 Hr).

5. **Building Units* — For 1 Hr Rating** — Nom 5/8 or 3/4 in. thick, 4 ft wide, faced gypsum board panels with the faced side on the interior wall cavity. Panels attached to studs and floor and ceiling runners with screws spaced 8 in. OC along the edges of the panel and 12 in. OC in the field of the panel. Joints oriented vertically and staggered on opposite sides of the assembly.

MOMENTIVE PERFORMANCE MATERIALS — Type CoreGuard.

6. **Joint Tape and Compound** — (Not Shown) — Vinyl, dry or premixed joint compound, applied in two coats to joints and screw heads; paper tape, 2 in. wide, embedded in first layer of compound over all joints.

7. **Gypsum Board* — For 2 Hr Rating — Any 5/8 in. thick UL Classified Gypsum Board that is eligible for use in Design Nos. L501, G512 or U305.** Nom. 5/8 in. thick, 4 ft wide, gypsum board applied over exterior face of Building Unit (Item 5). Gypsum board to be applied vertically with joints staggered 24 in. from Building Unit (Item 5) and attached to studs and floor and ceiling runners with screws spaced 8 in. OC.

AMERICAN GYPSUM CO ([View Classification](#)) — CKNX.R14196

BEIJING NEW BUILDING MATERIALS PUBLIC LTD CO ([View Classification](#)) — CKNX.R19374

CABOT MANUFACTURING ULC ([View Classification](#)) — CKNX.R25370

CERTAINTED GYPSUM INC ([View Classification](#)) — CKNX.R3660

CGC INC ([View Classification](#)) — CKNX.R19751

CERTAINTED GYPSUM INC ([View Classification](#)) — CKNX.R18482

GEORGIA-PACIFIC GYPSUM L L C ([View Classification](#)) — CKNX.R2717

GEORGIA-PACIFIC GYPSUM L L C ([View Classification](#)) — CKNX.R6937

LOADMASTER SYSTEMS INC ([View Classification](#)) — CKNX.R11809

NATIONAL GYPSUM CO ([View Classification](#)) — CKNX.R3501

PABCO BUILDING PRODUCTS L L C, DBA PABCO GYPSUM ([View Classification](#)) — CKNX.R7094

PANEL REY S A ([View Classification](#)) — CKNX.R21796

SIAM GYPSUM INDUSTRY (SARABURI) CO LTD ([View Classification](#)) — CKNX.R19262

THAI GYPSUM PRODUCTS PCL ([View Classification](#)) — CKNX.R27517

UNITED STATES GYPSUM CO ([View Classification](#)) — CKNX.R1319

USG MEXICO S A DE C V ([View Classification](#)) — CKNX.R16089

7. Barrier Mesh — (Optional, Not Shown) - Attached to steel studs on one or both sides of the wall using Barrier Mesh Clips spaced at maximum 12 inches on center vertically, using a flat head type screw penetrating through the steel at least 3/8 of an inch. For Steel Studs less than 0.033 inches in thickness, use self-piercing screws. For Steel Studs equal to or greater than 0.033 inches in thickness, use steel drill screws (self-tapping). Building Units (Item 5) and Gypsum Board (Item 7) to be installed directly over the Barrier Mesh using prescribed screw patterns with lengths increased by a minimum 1/8 in. Barrier Mesh may be installed with the long dimension of the diamond pattern positioned vertically or horizontally. Barrier Mesh joints may occur as butt joints at the framing members and secured using the Barrier Mesh Clips or occur in between framing members as overlapping joints secured using 18 SWG wire ties spaced a maximum 12 in. on center.

CLARKDIETRICH BUILDING SYSTEMS — Barrier Mesh, Barrier Mesh Clips

*** Indicates such products shall bear the UL or cUL Certification Mark for jurisdictions employing the UL or cUL Certification (such as Canada), respectively.**

Last Updated on 2020-12-31

La presencia del nombre de una empresa o producto en esta base de datos no garantiza por sí misma que los productos así identificados hayan sido fabricados bajo el servicio de seguimiento de UL. Solo aquellos productos que lleven la marca UL deben considerarse como certificados y garantizados bajo el servicio de seguimiento de UL. Busque siempre la marca en el producto.

UL permite la reproducción del material contenido en el directorio de certificación en línea sujeta a las siguientes condiciones: 1. La información de la guía, las ensamblajes, las construcciones, los diseños, los sistemas y/o certificaciones (archivos) deben presentarse en su totalidad y de forma no engañosa, sin ninguna manipulación en los datos (o dibujos). 2. Debe aparecer la declaración "Reimpreso desde el directorio de certificaciones en línea con permiso de UL" junto al material extraído. Además, el material reimpreso debe incluir una nota de derechos de autor en el siguiente formato: "© 2021 UL LLC"