

BXUV.U348



Design/System/Construction/Assembly Usage Disclaimer

- Authorities Having Jurisdiction should be consulted in all cases as to the particular requirements covering the installation and use of UL Certified products, equipment, system, devices, and materials.
- Authorities Having Jurisdiction should be consulted before construction.
- Fire resistance assemblies and products are developed by the design submitter and have been investigated by UL for compliance with applicable requirements. The published information cannot always address every construction nuance encountered in the field.
- When field issues arise, it is recommended the first contact for assistance be the technical service staff provided by the product manufacturer noted for the design. Users of fire resistance assemblies are advised to consult the general Guide Information for each product category and each group of assemblies. The Guide Information includes specifics concerning alternate materials and alternate methods of construction.
- Only products which bear UL's Mark are considered Certified.

Design No. U348

May 28, 2021

Bearing Wall Rating - 1 Hr Rating Exposed to Fire on Interior Face Only (See Item 6 and 7)

Bearing Wall Rating - 1 Hr Rating Exposed to Fire on Either Face (See Item 8)

For Wood Studs, Finish Rating – 23 min (Exposed to Fire on Interior Face)

This design was evaluated using a load design method other than the Limit States Design Method (e.g., Working Stress Design Method). For jurisdictions employing the Limit States Design Method, such as Canada, a load restriction factor shall be used – See Guide [BXUV](#) or [BXUV7](#)

*** Indicates such products shall bear the UL or cUL Certification Mark for jurisdictions employing the UL or cUL Certification (such as Canada), respectively.**

1-HOUR
(FIRE FROM INTERIOR ONLY)

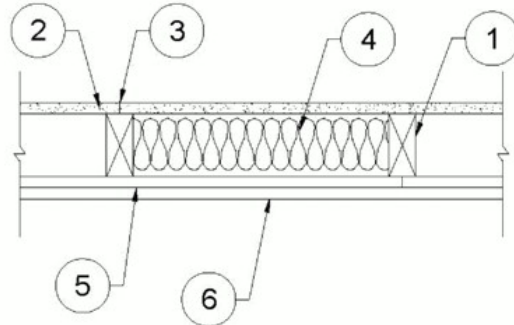

1-HOUR
(FIRE FROM EITHER FACE)

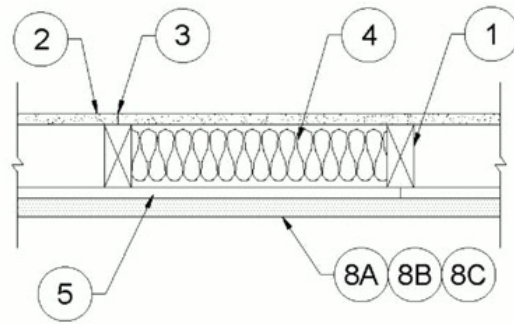

1. **Wood Studs** — Nom 2 by 4 in., spaced 16 in. OC in with two 2 by 4 top and one 2 by 4 bottom plates. As an option, nom 2 by 6 in., spaced 24 in. OC with two 2 by 6 top and one 2 by 6 bottom plates may be used in lieu of 2 by 4 studs and plates. Studs effectively fire stopped.

1A. Steel Studs and Floor and Ceiling Tracks — As an option to Item 1 — (Not Shown) — Top and bottom tracks of wall assemblies shall consist of steel members, min No. 20 MSG (0.0329 in., min bare metal thickness) steel or min No. 20 MSG (0.036 in. thick) galv steel or No. 20 MSG (0.033 in. thick) primed steel, that provide a sound structural connection between steel studs, and to adjacent assemblies such as a floor, ceiling, and/or other walls. Attached to floor and ceiling assemblies with steel fasteners spaced not greater than 24 in. O.C. Steel studs min 3-1/2 in. wide, No. 20 MSG (0.0329 in., min bare metal thickness) corrosion protected cold formed steel studs designed in accordance with the current edition of the Specification for the Design of Cold-Formed Steel Structural Members by the American Iron and Steel Institute. All design details enhancing the structural integrity of the wall assembly, including the axial design load of the studs, shall be as specified by the steel stud designer and/or producer, and shall meet the requirements of all applicable local code agencies. The max stud spacing of wall assemblies shall not exceed 24 in. OC. Studs attached to floor and ceiling tracks with 1/2 in. long Type S-12 steel screws on both sides of studs or by welded or bolted connections designed in accordance with the AISI specifications.

2. Gypsum Board* — **Any 5/8 in. thick UL Classified Gypsum Board that is eligible for use in Design Nos. L501, G512 or U305.** Nom. 5/8 in. thick, 4 ft. wide, applied vertically, and nailed to studs and bearing plates 7 in. OC. with 6d cement coated nails, 1-7/8 in. long, 0.0915 in. shank diam. and 1/4 in. diam. head. When steel framing is substituted for wood framing, 1 in. long Type S steel screws are used in lieu of nails.

CABOT MANUFACTURING ULC ([View Classification](#)) — CKNX.R25370

AMERICAN GYPSUM CO ([View Classification](#)) — CKNX.R14196

BEIJING NEW BUILDING MATERIALS PUBLIC LTD CO ([View Classification](#)) — CKNX.R19374

CERTAINTED GYPSUM INC ([View Classification](#)) — CKNX.R3660

CGC INC ([View Classification](#)) — CKNX.R19751

GEORGIA-PACIFIC GYPSUM L L C ([View Classification](#)) — CKNX.R2717

CERTAINTED GYPSUM INC ([View Classification](#)) — CKNX.R18482

LOADMASTER SYSTEMS INC ([View Classification](#)) — CKNX.R11809

NATIONAL GYPSUM CO ([View Classification](#)) — CKNX.R3501

PABCO BUILDING PRODUCTS L L C, DBA PABCO GYPSUM ([View Classification](#)) — CKNX.R7094

PANEL REY S A ([View Classification](#)) — CKNX.R21796

SIAM GYPSUM INDUSTRY (SARABURI) CO LTD ([View Classification](#)) — CKNX.R19262

GEORGIA-PACIFIC GYPSUM L L C ([View Classification](#)) — CKNX.R6937

THAI GYPSUM PRODUCTS PCL ([View Classification](#)) — CKNX.R27517

UNITED STATES GYPSUM CO ([View Classification](#)) — CKNX.R1319

USG MEXICO S A DE C V ([View Classification](#)) — CKNX.R16089

3. Joints and Nailheads — Wallboard joints covered with tape and joint compound. Nail heads covered with joint compound.

4. **Batts and Blankets*** — Faced or unfaced mineral fiber insulation, 3-1/2 in. thick, nom 3.0 pcf, pressure fit in the wall cavity between stud, plates, and cross bracing. If 2 by 6 in. studs (Item 1) are used, min. 5-1/2 in. of unfaced mineral fiber insulation, nom 3.0 pcf, pressure fit in the wall cavity between stud, plates, and cross bracing. Insulation may be applied in multiple layers to achieve final thickness.

See **Batts and Blankets*** (BZJZ) category for names of Classified manufacturers.

4A. **Batts and Blankets*** — As an Alternate to Item 4 when wood studs are used. - As an Alternate to Item 4 when steel studs are used, but Optional Items 7A or 7B are required. Faced or unfaced glass fiber batts, 3-1/2 in. thick, having a min density of 0.9 pcf (min R-13 thermal insulation rating), pressure fit in the wall cavity between stud, plates, and cross bracing.

See **Batts and Blankets*** (BZJZ) category for names of Classified manufacturers.

4B. **Fiber, Sprayed*** — As an Alternate to Item 4 when wood studs are used. - As an Alternate to Item 4 when steel studs are used, but Optional Items 7A or 7B are required.— (100% Borate Formulation) — Spray applied cellulose material. The fiber is applied with water to completely fill the enclosed cavity in accordance with the application instructions supplied with the product with a nominal dry density of 2.7 lb/ft³. Alternate Application Method: The fiber is applied without water or adhesive at a nominal dry density of 3.5 lb/ft³, in accordance with the application instructions supplied with the product.

U S GREENFIBER L L C — INS735, NS745 and INS750LD for use with wet or dry application. INS765LD and INS773LD are to be used for dry application only.

4C. **Fiber, Sprayed*** — As an Alternate to Item 4 when wood studs are used. - As an Alternate to Item 4 when steel studs are used, but Optional Items 7A or 7B are required.- Spray applied cellulose fiber. The fiber is applied with water to completely fill the enclosed cavity in accordance with the application instructions supplied with the product. The minimum dry density shall be 4.30 lbs/ft³.

INTERNATIONAL CELLULOSE CORP — Celbar-RL

4D. **Fiber, Sprayed*** — As an Alternate to Item 4 when wood studs are used. - As an Alternate to Item 4 when steel studs are used, but Optional Items 7A or 7B are required.— Spray applied cellulose insulation material. The fiber is applied with water to interior surfaces in accordance with the application instructions supplied with the product. Applied to completely fill the enclosed cavity. Minimum dry density of 4.3 pounds per cubic ft.

NU-WOOL CO INC — Cellulose Insulation

5. **Building Units*** — Building units placed with the laminate face against or laminate face away from, and nailed to, the wood framing with 1-7/8 in. long, 6d nails, spaced 6 in. OC. on the perimeter and 12 in. OC. in the field. When steel framing is substituted for wood framing, Type S steel screws are used in lieu of nails with a minimum penetration length through the steel stud of 3/8 in.

LOUISIANA-PACIFIC CORP — Type Blazeguard 1-Side

LOUISIANA-PACIFIC CORP — Type LP FlameBlock 1-Side

6. **Exterior Facings** — (For use with Wood Studs, Item 1) - Any exterior facing approved by the Authority Having Jurisdiction installed in accordance with the manufacturer's installation instructions.

7. **Exterior Facings** — (Not Shown) (For use with steel Studs, Item 1A, but limited to the use of Mineral Wool Insulation Item 4) - Any exterior facing approved by the Authority Having Jurisdiction installed in accordance with the manufacturer's installation instructions.

7A. **Cementitious Stucco** — (Optional unless Item 1A, Steel Studs, are used in conjunction with Item 4A, 4B, 4C or 4D Batts and Blankets - Not Shown) - Portland cement or synthetic stucco systems with self-furring metal lath or adhesive base coat. Thickness from 1/2 in. to 3/4 in. depending on system.

7B. **Brick Veneer** — (Optional unless Item 1A, Steel Studs, are used in conjunction with Item 4A, 4B 4C or 4D Batts and Blankets - Not Shown) Brick veneer, minimum thickness of 2.3 inches, meeting the requirements of local code agencies. When brick veneer is used, the rating is applicable with exposure on either face. Brick veneer fastened with corrugated metal wall ties attached over sheathing to wood studs with 8d nail per tie: ties spaced not more than each sixth course of brick and max 32 in. OC horizontally. One in. air space provided between brick veneer and sheathing. For steel studs, Type S steel screws are used in lieu of nails with a minimum penetration length through the steel stud of 3/8 in.

8. **Exterior Facings** — (Not Shown) — Required for 1 Hour Rating on the Exterior Face. The following exterior facing shall be installed in accordance with the manufacturer's installation instructions:

8A. **Brick** — Brick veneer, minimum thickness of 2.3 inches, meeting the requirements of local code agencies. Brick veneer attached to the studs with corrugated metal wall ties attached to each stud with 8d cement coated nails, every sixth course of bricks and max 32 in. OC horizontally. One in. air space provided between brick veneer and sheathing. For steel studs, Type S steel screws are used in lieu of nails with a minimum penetration length through the steel stud of 3/8 in.

8B. **Cementitious Stucco** — Portland cement with self-furring metal lath. Minimum thickness of 3/4 in. with a mix ratio of 1:4 for scratch coat and 1:5 for brown coat, by volume, cement to sand.

8C. **Gypsum Board*** — Nom. 5/8 in. thick, 4 ft. wide exterior sheathing applied vertically. Single layer nailed to wood studs and bearing plates 6 in. OC with 1-7/8 in. long 6d cement coated nails. Vertical joints centered over studs and staggered min. 1 stud cavity from the vertical joints of the building units (Item #5). The joints and nail heads do not need to be treated with joint compound.
GEORGIA-PACIFIC GYPSUM L L C — Types DGG

*** Indicates such products shall bear the UL or cUL Certification Mark for jurisdictions employing the UL or cUL Certification (such as Canada), respectively.**

La presencia del nombre de una empresa o producto en esta base de datos no garantiza por sí misma que los productos así identificados hayan sido fabricados bajo el servicio de seguimiento de UL. Solo aquellos productos que lleven la marca UL deben considerarse como certificados y garantizados bajo el servicio de seguimiento de UL. Busque siempre la marca en el producto.

UL permite la reproducción del material contenido en el directorio de certificación en línea sujeta a las siguientes condiciones: 1. La información de la guía, las ensamblajes, las construcciones, los diseños, los sistemas y/o certificaciones (archivos) deben presentarse en su totalidad y de forma no engañosa, sin ninguna manipulación en los datos (o dibujos). 2. Debe aparecer la declaración "Reimpreso desde el directorio de certificaciones en línea con permiso de UL" junto al material extraído. Además, el material reimpreso debe incluir una nota de derechos de autor en el siguiente formato: "© 2021 UL LLC"