

BXUV.U339 - Fire-resistance Ratings - ANSI/UL 263



Design/System/Construction/Assembly Usage Disclaimer

- Authorities Having Jurisdiction should be consulted in all cases as to the particular requirements covering the installation and use of UL Certified products, equipment, system, devices, and materials.
- Authorities Having Jurisdiction should be consulted before construction.
- Fire resistance assemblies and products are developed by the design submitter and have been investigated by UL for compliance with applicable requirements. The published information cannot always address every construction nuance encountered in the field.
- When field issues arise, it is recommended the first contact for assistance be the technical service staff provided by the product manufacturer noted for the design. Users of fire resistance assemblies are advised to consult the general Guide Information for each product category and each group of assemblies. The Guide Information includes specifics concerning alternate materials and alternate methods of construction.
- Only products which bear UL's Mark are considered Certified.

BXUV - Fire Resistance Ratings - ANSI/UL 263 Certified for United States

BXUV7 - Fire Resistance Ratings - CAN/ULC-S101 Certified for Canada

[See General Information for Fire-resistance Ratings - ANSI/UL 263 Certified for United States Design Criteria and Allowable Variances](#)

[See General Information for Fire Resistance Ratings - CAN/ULC-S101 Certified for Canada Design Criteria and Allowable Variances](#)

Design No. U339

March 11, 2020

Nonbearing or Bearing Wall Rating — 1 HR.

(See Items 2 and 2A)

Finish Rating — One Layer of Wallboard — Min 20 Min.

Two Layers of Wallboard — Min 59 Min.

This design was evaluated using a load design method other than the Limit States Design Method (e.g., Working Stress Design Method). For jurisdictions employing the Limit States Design Method, such as Canada, a load restriction factor shall be used — See Guide [BXUV](#) or [BXUV7](#)

*** Indicates such products shall bear the UL or cUL Certification Mark for jurisdictions employing the UL or cUL Certification (such as Canada), respectively.**

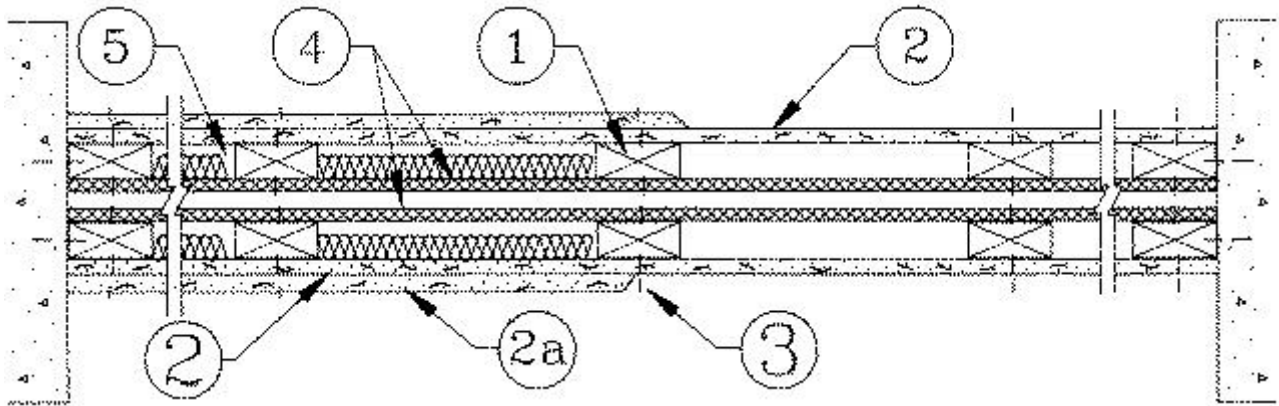

HORIZONTAL SECTION

1. **Wood Studs** — Nom 2 by 3 or 2 by 4 in., flat wise, spaced 24 in. O.C. max, effectively firestopped.

2. **Gypsum Board*** — Any 5/8 in. thick UL Classified Gypsum Board that is eligible for use in Design Nos. L501, G512 or U305. For Nonbearing Wall rating — One layer of 5/8 in. thick gypsum board secured to each side of assembly. Gypsum board applied horizontally or vertically, unless specified below, and nailed to studs and bearing plates 7 in. O.C. with 6d cement coated nails, 1-7/8 in. long, 0.0915 in. shank diam and 1/4 in. diam head. As an alternate, No. 6 bugle head drywall screws, 1-7/8 in. long, may be substituted for the 6d cement coated nails. When used in widths other than 48 in., gypsum board to be installed horizontally.

AMERICAN GYPSUM CO ([View Classification](#)) — CKNX.R14196

BEIJING NEW BUILDING MATERIALS PUBLIC LTD CO ([View Classification](#)) — CKNX.R19374

CABOT MANUFACTURING ULC ([View Classification](#)) — CKNX.R25370

CERTAINTED GYPSUM INC ([View Classification](#)) — CKNX.R3660

CGC INC ([View Classification](#)) — CKNX.R19751

CERTAINTED GYPSUM INC ([View Classification](#)) — CKNX.R18482

GEORGIA-PACIFIC GYPSUM L L C ([View Classification](#)) — CKNX.R2717

LOADMASTER SYSTEMS INC ([View Classification](#)) — CKNX.R11809

NATIONAL GYPSUM CO ([View Classification](#)) — CKNX.R3501

PABCO BUILDING PRODUCTS L L C, DBA PABCO GYPSUM ([View Classification](#)) — CKNX.R7094

PANEL REY S A ([View Classification](#)) — CKNX.R21796

SIAM GYPSUM INDUSTRY (SARABURI) CO LTD ([View Classification](#)) — CKNX.R19262

THAI GYPSUM PRODUCTS PCL ([View Classification](#)) — CKNX.R27517

UNITED STATES GYPSUM CO ([View Classification](#)) — CKNX.R1319

USG BORAL DRYWALL SFZ LLC ([View Classification](#)) — CKNX.R38438

USG MEXICO S A DE C V ([View Classification](#)) — CKNX.R16089

2A. **Gypsum Board*** — Same as Item 2. For Bearing Wall rating — Additional layer of 5/8 in. thick, 4 ft wide wallboard each side of assembly. Attached to studs over inner layer 8 in. O.C. max with 8d cement coated nails, 2-3/8 in. long, 0.113 in. shank diam and 9/32 in. diam head.

2B. **Gypsum Board*** — (As an alternate to Item 2, not shown) - For Nonbearing Wall rating - Any 5/8 in. thick gypsum panels that are eligible for use in Design Nos. L501, G512 or U305, supplied by the Classified companies listed below shown in the **Gypsum Board*** (CKNX) category. Applied horizontally or vertically and attached to studs and bearing plates with 1-1/4 in. long Type W coarse thread gypsum panel steel screws spaced a max 8 in. OC, with last screw 1 in. from edge of board. When used in widths other than 48 in., gypsum board to be installed horizontally.

CGC INC

UNITED STATES GYPSUM CO

USG BORAL DRYWALL SFZ LLC

USG MEXICO S A DE C V

2C. **Gypsum Board*** — Same as Item 2B. For Bearing Wall rating — Additional layer of 5/8 in. thick, 4 ft wide wallboard each side of assembly. Attached to studs over inner layer 8 in. O.C. max with 1-7/8 in. long Type W coarse thread gypsum panel steel screws.

2D. **Gypsum Board*** — (As an alternate to Item 2, not shown) - For Nonbearing Wall rating - 5/8 in. thick gypsum panels applied horizontally or vertically and attached to studs and bearing plates with 1-1/4 in. long Type W coarse thread gypsum panel steel screws spaced a max 8 in. OC, with last screw 1 in. from edge of board. When used in widths other than 48 in., gypsum board to be installed horizontally.

AMERICAN GYPSUM CO — Types AGX-1, M-Glass, AG-C, LightRoc

CABOT MANUFACTURING ULC — Type X, 5/8 Type X

CERTAINTED GYPSUM INC — Type C, Type X or Type X-1

NATIONAL GYPSUM CO — Type FSK, Type FSK-G, Type FSW, Type FSW-3, Type FSW-5, Type FSW-G, Type FSK-C, Type FSW-C, Type FSMR-C, Type FSW-6, Type FSL

THAI GYPSUM PRODUCTS PCL — Type C or Type X

2E. **Gypsum Board*** — Same as Item 2D. For Bearing Wall rating — Additional layer of 5/8 in. thick, 4 ft wide wallboard each side of assembly. Attached to studs over inner layer 8 in. O.C. max with 1-7/8 in. long Type W coarse thread gypsum panel steel screws.

AMERICAN GYPSUM CO — Types AGX-1, M-Glass, AG-C, LightRoc

CABOT MANUFACTURING ULC — Type X

CERTAINTED GYPSUM INC — Type C or Type X

THAI GYPSUM PRODUCTS PCL — Type C or Type X

2F. Gypsum Board* — (As an alternate to Item 2, not shown) - For Nonbearing Wall rating - 5/8 in. thick gypsum panels, with square edges, applied either horizontally or vertically. Gypsum panels fastened to framing with 1-1/4 in. long Type W coarse thread gypsum panel steel screws spaced a max 8 in. OC, with last 2 screws 1 and 4 in. from edge of board or nailed as described in Item 3. When used in widths of other than 48 in., gypsum boards are to be installed horizontally.

GEORGIA-PACIFIC GYPSUM L L C — GreenGlass Type X, Type DGG.

2G. Gypsum Board* — Same as Item 2F. For Bearing Wall rating — Additional layer of 5/8 in. thick, 4 ft wide wallboard each side of assembly. Attached to studs over inner layer 8 in. O.C. max with 1-7/8 in. long Type W coarse thread gypsum panel steel screws.

GEORGIA-PACIFIC GYPSUM L L C — GreenGlass Type X, Type DGG.

2H. Gypsum Board* — (As an alternate to Items 2, 2A, 2B, 2C, 2D, 2E, 2F and 2H) - 5/8 in. glass-mat faced with square edges, applied either horizontally or vertically. Gypsum panels nailed 7 in. OC with 6d cement coated nails 1-7/8 in. long, 0.0915 in. shank diam and 15/64 in. diam heads.

CGC INC — Type USGX (finish rating 22 min).

UNITED STATES GYPSUM CO — Type USGX (finish rating 22 min).

USG BORAL DRYWALL SFZ LLC — Type USGX (finish rating 22 min).

USG MEXICO S A DE C V — Type USGX (finish rating 22 min).

2I. Gypsum Board* — (As an alternate to Item 2, not shown) - For Nonbearing Wall rating - 5/8 in. thick, 4 ft. wide, paper surfaced applied vertically only and secured as described in Item 2.

GEORGIA-PACIFIC GYPSUM L L C — Type X ComfortGuard Sound Deadening Gypsum Board

2J. Gypsum Board* — Same as Item 2I. For Bearing Wall rating — Additional layer of 5/8 in. thick, 4 ft wide paper surfaced applied vertically only and secured as described in Item 2A.

GEORGIA-PACIFIC GYPSUM L L C — Type X ComfortGuard Sound Deadening Gypsum Board

2K. Gypsum Board* — (As an alternate to Item 2) - For Nonbearing Wall rating - 5/8 in. thick, 4 ft. wide, paper surfaced applied vertically only and secured as described in Item 2. For Bearing Wall rating — Additional layer of 5/8 in. thick, 4 ft wide paper surfaced applied vertically only and secured as described in Item 2A.

NATIONAL GYPSUM CO — Type SBWB

2L. Gypsum Board* — (As an alternate to Items 2 through 2K) — Nominal 5/8 in. thick, 4 ft wide panels, applied vertically and secured as described in Items 2 or 2A.

PABCO BUILDING PRODUCTS L L C, DBA PABCO GYPSUM — Type QuietRock ES.

2M. Gypsum Board* — (As an alternate to Item 2) - For Nonbearing Wall rating - 5/8 in. thick, 4 ft. wide, paper surfaced applied vertically or horizontally and secured with 1-1/4 in. long Type W coarse thread gypsum panel steel screws spaced a

max 8 in. OC, with last screw 1 in. from edge of board.

CERTAINTED GYPSUM INC — Type SilentFX

2N. Wall and Partition Facings and Accessories* — (As an alternate to Items 2 through 2L) — Nominal 5/8 in. thick, 4 ft wide panels, applied vertically and secured as described in Item 2 or 2A.

PABCO BUILDING PRODUCTS L L C, DBA PABCO GYPSUM — Type QuietRock 527.

2O. Gypsum Board* — (As an alternate to 5/8 in. Type FSW in Item 2) - 2 layers nom. 5/16 in. thick gypsum panels applied vertically or horizontally. Horizontal joints on the same side need not be staggered. Inner layer attached with fasteners, as described in item 2, spaced 24 in. OC. Outer layer attached per Item 2.

NATIONAL GYPSUM CO — Type FSW.

2P. Gypsum Board* — (As an alternate to Item 2) — For Non-Bearing wall rating of 1 hr. Single layer 5/8 in. thick gypsum panels, with beveled, square, or tapered edges, applied either horizontally or vertically. Gypsum panels fastened to framing with 1-1/4 in. long Type W coarse thread gypsum panel steel screws spaced a maximum 10 in. OC with the last two screws 4 and 1 in. from the edges of the board. When used in widths other than 48 in., gypsum panels are to be installed horizontally.

CERTAINTED GYPSUM INC — Type LGFC6A (finish rating 21 min), Type LGFC2A, Type LGFC-C/A, Type LGFC-WD, Type LGLLX

2Q. Gypsum Board* — — (As an alternate to Item 2A) — For bearing wall rating. Double layers 5/8 in. thick, two layers applied either horizontally or vertically. Inner layer attached to studs with 1-1/4 in. long Type W steel screws spaced 10 in. OC with the last two screws 4 and 1 in. from the edges of the board. Outer layer attached to studs over inner layer with 1-7/8 in. long Type W steel screws spaced 10 in. OC offset 5 in. from base layer with the last two screws 4 and 1 in. from the edges of the board. Vertical joints located over studs. Vertical and horizontal joints between inner and outer layers staggered. Outer layer joints covered with joint tape and compound, screwheads covered with joint compound. When used in widths other than 48 in., gypsum panels are to be installed horizontally.

CERTAINTED GYPSUM INC — Type LGFC6A, Type LGFC2A, Type LGFC-C/A, Type LGFC-WD, Type LGLLX

3. Joints and Nail Heads — Gypsum board joints of outer layer covered with paper tape and joint compound. Nail heads of outer layer covered with joint compound. As an alternate, nom 3/32 in. thick gypsum veneer plaster may be applied to the entire surface of Classified veneer baseboard with joints reinforced with paper tape.

4. Sheathing — Septum shall be sheathed with plywood or Mineral and Fiber Boards*. For walls with two layers of gypsum board on both sides sheathing is optional.

See **Mineral and Fiber Boards*** (CERZ) category for names of Classified companies.

5. Batts and Blankets* — (Optional) — Max 1 in. thickness glass or mineral fiber batt insulation.

See **Batts and Blankets*** (BZJZ) category for names of Classified companies.

5A. Fiber, Sprayed* — As an alternate to Batts and Blankets (Item 5) — Spray applied cellulose material. The fiber is applied with water to completely fill the enclosed cavity in accordance with the application instructions supplied with the product with a nominal dry density of 2.7 lb/ft³. Alternate Application Method: The fiber is applied without water or adhesive at a nominal dry density of 3.5 lb/ft³, in accordance with the application instructions supplied with the product.

U S GREENFIBER L L C — INS735, INS745 and INS750LD for use with wet or dry application. INS515LD, INS541LD, INS735, INS765LD, and INS773LD are to be used for dry application only.

5B. Fiber, Sprayed* — As an alternate to Batts and Blankets (Item 5) and Item 5A - Spray applied cellulose insulation material. The fiber is applied with water to interior surfaces in accordance with the application instructions supplied with the product. Applied to completely fill the enclosed cavity. Minimum dry density of 4.3 pounds per cubic ft.

NU-WOOL CO INC — Cellulose Insulation

5C. Fiber, Sprayed* — As an alternate to Batts and Blankets (Item 5) - Spray applied cellulose fiber. The fiber is applied with water to completely fill the enclosed cavity in accordance with the application instructions supplied with the product. The minimum dry density shall be 4.30 lbs/ft³.

INTERNATIONAL CELLULOSE CORP — Celbar-RL

5D. Fiber, Sprayed* — As an alternate to Batts and Blankets (Item 5) - Spray-applied cellulose material. The fiber is applied with water to completely fill the enclosed cavity in accordance with the application instructions supplied with the product. To facilitate the installation of the material, any thin, woven or non-woven netting may be attached by any means possible to the outer face the studs. The material shall reach equilibrium moisture content before the installation of materials on either face of the studs. The minimum dry density shall be 5.79 lbs/ft³.

APPLEGATE HOLDINGS L L C — Applegate Advanced Stabilized Cellulose Insulation

*** Indicates such products shall bear the UL or cUL Certification Mark for jurisdictions employing the UL or cUL Certification (such as Canada), respectively.**

Last Updated on 2020-03-11

La presencia del nombre de una empresa o producto en esta base de datos no garantiza por sí misma que los productos así identificados hayan sido fabricados bajo el servicio de seguimiento de UL. Solo aquellos productos que lleven la marca UL deben considerarse como certificados y garantizados bajo el servicio de seguimiento de UL. Busque siempre la marca en el producto.

UL permite la reproducción del material contenido en el directorio de certificación en línea sujeta a las siguientes condiciones: 1. La información de la guía, las ensamblajes, las construcciones, los diseños, los sistemas y/o certificaciones (archivos) deben presentarse en su totalidad y de forma no engañosa, sin ninguna manipulación en los datos (o dibujos). 2. Debe aparecer la declaración "Reimpreso desde el directorio de certificaciones en línea con permiso de UL" junto al material extraído. Además, el material reimpreso debe incluir una nota de derechos de autor en el siguiente formato: "© 2021 UL LLC"