

BXUV.L542



Design/System/Construction/Assembly Usage Disclaimer

- Authorities Having Jurisdiction should be consulted in all cases as to the particular requirements covering the installation and use of UL Certified products, equipment, system, devices, and materials.
- Authorities Having Jurisdiction should be consulted before construction.
- Fire resistance assemblies and products are developed by the design submitter and have been investigated by UL for compliance with applicable requirements. The published information cannot always address every construction nuance encountered in the field.
- When field issues arise, it is recommended the first contact for assistance be the technical service staff provided by the product manufacturer noted for the design. Users of fire resistance assemblies are advised to consult the general Guide Information for each product category and each group of assemblies. The Guide Information includes specifics concerning alternate materials and alternate methods of construction.
- Only products which bear UL's Mark are considered Certified.

BXUV - Fire Resistance Ratings - ANSI/UL 263 Certified for United States

BXUV7 - Fire Resistance Ratings - CAN/ULC-S101 Certified for Canada

Design No. L542

Unrestrained Assembly Rating – 1 Hr

This design was evaluated using a load design method other than the Limit States Design Method (e.g., Working Stress Design Method). For jurisdictions employing the Limit States Design Method, such as Canada, a load restriction factor shall be used – See Guide [BXUV](#) or [BXUV7](#)

*** Indicates such products shall bear the UL or cUL Certification Mark for jurisdictions employing the UL or cUL Certification (such as Canada), respectively.**

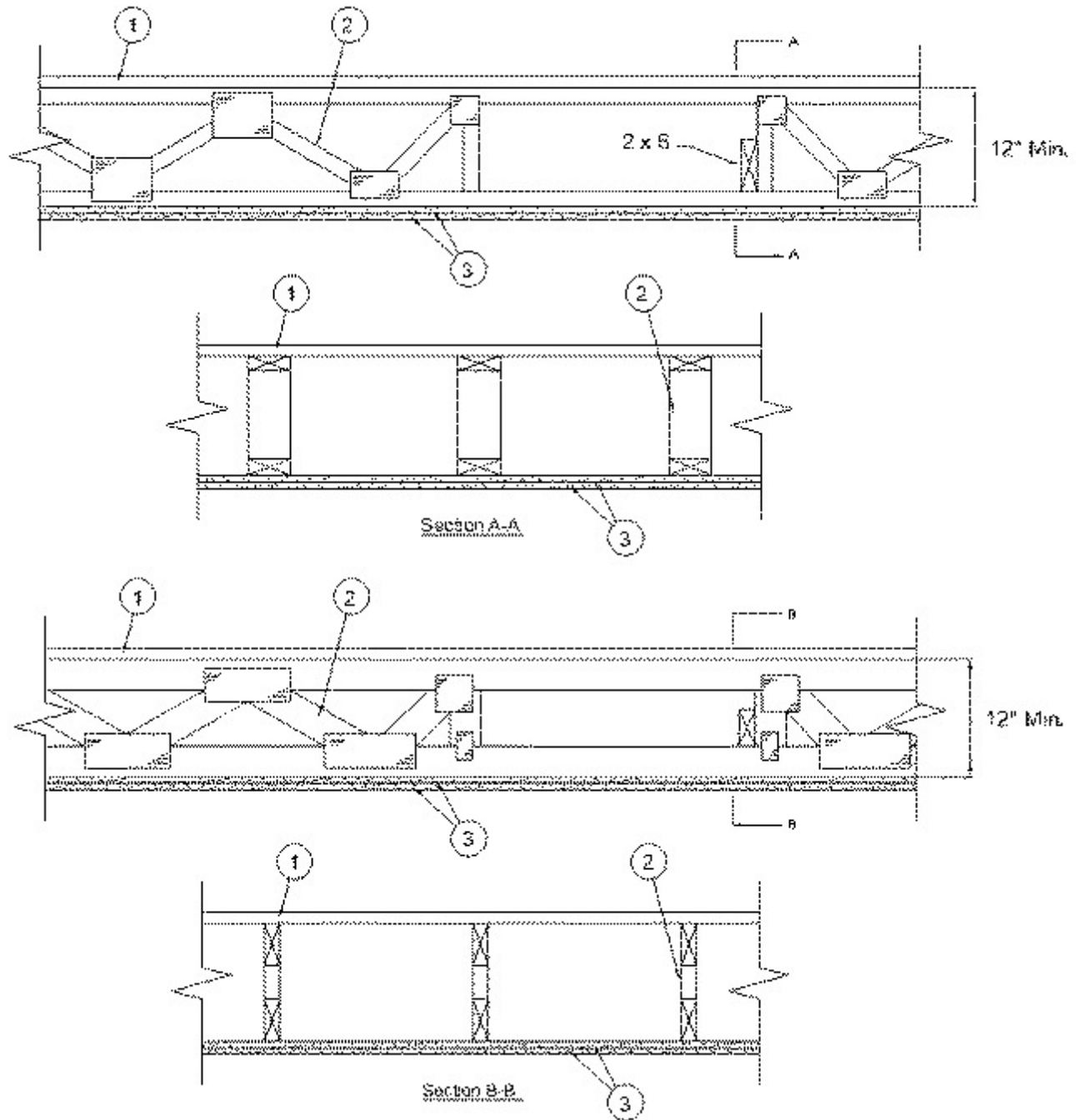

1. **Flooring System** — The flooring system shall consist of one of the following:

System No. 1

Subflooring — Min 23/32 in. thick T & G wood structural panels, min grade "Underlayment" or "Single-Floor". Face grain of plywood or strength axis of panel to be perpendicular to the trusses with end joints staggered 4 ft. Plywood or panels secured to trusses with construction adhesive and No. 6d cement coated nails spaced 12 in. OC along each truss. Adhesive applied as 3/8 in. diam bead to top chord of trusses and grooved edges of plywood or panel.

System No. 2

Subflooring — Min 23/32 in. thick T & G wood structural panels, min grade "Underlayment" or "Single-Floor". Face grain of plywood or strength axis of panel to be perpendicular to the trusses with end joints staggered 4 ft. Plywood or panels secured to trusses with construction adhesive and No. 6d cement coated nails spaced 12 in. OC along each truss. Adhesive applied as 3/8 in. diam bead to top chord of trusses and grooved edges of plywood or panel.

Floor Mat Materials* — (Optional) — Floor mat material nom 5/64 in. (2 mm) thick adhered to subfloor with Hacker Floor Primer. Primer to be applied to the surface of the mat prior to the placement of a min 1-1/4 in. of floor-topping mixture.

HACKER INDUSTRIES INC — Type Hacker Sound-Mat.

Alternate Floor Mat Materials — (Optional) — Floor mat material nom 1/4 in. (6 mm) thick adhered to subfloor with Hacker Floor Primer. Primer to be applied to the surface of the mat prior to the placement of a min 1-1/4 in. (32 mm) of floor-topping mixture.

HACKER INDUSTRIES INC — Type Hacker Sound-Mat II.

Alternate Floor Mat Materials — (Optional) — Floor mat material nom 1/8 in. (3 mm) thick loose laid over the subfloor. Floor topping thickness shall be a min of 1 in. (25 mm)

HACKER INDUSTRIES INC — FIRM-FILL SCM 125

Alternate Floor Mat Materials — (Optional) — Floor mat material nom 1/4 in. (6 mm) thick loose laid over the subfloor. Floor topping thickness shall be a min of 1 in. (25 mm)

HACKER INDUSTRIES INC — Type FIRM-FILL SCM 250, Quiet Qurl 55/025

Alternate Floor Mat Materials — (Optional) — Floor mat material nom 3/8 in. (10 mm) thick loose laid over the subfloor. Floor topping thickness shall be a min of 1-1/4 in. (32 mm)

HACKER INDUSTRIES INC — FIRM-FILL SCM 400, Quiet Qurl 60/040

Alternate Floor Mat Materials — (Optional) — Floor mat material nom 3/4 in. (19 mm) thick loose laid over the subfloor. Floor topping thickness shall be a min of 1-1/2 in. (38 mm)

HACKER INDUSTRIES INC — Type FIRM-FILL SCM 750, Quiet Qurl 65/075

Metal Lath — (Optional) — For use with 3/8 in. (10 mm) floor mat materials, 3/8 in. expanded steel diamond mesh, 3.4 lbs/sq yd placed over the floor mat material. Hacker Floor Primer to be applied prior to the placement of the metal lath. When metal lath is used, floor topping thickness a nom 1-1/4 in. over the floor mat.

Finish Flooring — Floor Topping Mixture* — Min 1 in. thickness of floor topping mixture having a min compressive strength of 1100 psi. Mixture shall consist of 6.8 gal of water to 80 lbs of floor topping mixture to 1.9 cu ft of sand.

HACKER INDUSTRIES INC — Firm-Fill Gypsum Concrete, Firm-Fill 2010, Firm-Fill 3310, Firm-Fill 4010, Firm-Fill High Strength, Gyp-Span Radiant

System No. 3

Subflooring — Min 1 by 6 in. T & G lumber fastened diagonally to joists, or min 15/32 in. thick plywood or 7/16 in. thick oriented strand board (OSB) wood structural panels, min grade "C-D" or "Sheathing". Face grain of plywood or strength axis of panels to be perpendicular to the joists with joints staggered.

Finish Floor — Mineral and Fiber Board* — Min 1/2 in. thick, supplied in sizes ranging from 3 ft by 4 ft to 8 ft by 12 ft. All joints to be staggered a min of 12 in. with adjacent sub-floor joints.

HOMASOTE CO — Type 440-32 Mineral and Fiber Board

System No. 4

Subflooring — Min 23/32 in. thick T & G wood structural panels, min grade "Underlayment" or "Single-Floor". Face grain of plywood or strength axis of panel to be perpendicular to the trusses with end joints staggered 4 ft. Plywood or panels secured to trusses with construction adhesive and No. 6d cement coated nails spaced 12 in. OC along each truss. Adhesive applied as 3/8 in. diam bead to top chord of trusses and grooved edges of plywood or paneling.

Finish Flooring — Floor Topping Mixture* — Min 1-1/2 in. thickness of floor topping mixture having a min compressive strength of 1000 psi and a cast density of 100 plus or minus 5 pcf. Foam concentrate mixed 40:1 by volume with water and expanded at 100 psi through nozzle. Mixture shall consist of 1.4 cu feet of preformed foam concentrate to 94 lbs Type I Portland cement, 300 lbs of sand with 5-1/2 gal of water.

ELASTIZELL CORP OF AMERICA — Type FF

System No. 5

Subflooring — Min 23/32 in. thick T & G wood structural panels, min grade "Underlayment" or "Single-Floor". Face grain of plywood or strength axis of panel to be perpendicular to the trusses with end joints staggered 4 ft. Plywood or panels secured to trusses with construction adhesive and No. 6d cement coated nails spaced 12 in. OC along each truss. Adhesive applied as 3/8 in. diam bead to top chord of trusses and grooved edges of plywood or paneling.

Finish Flooring — Floor Topping Mixture* — Min 3/4 in. thickness of floor topping mixture having a minimum compressive strength of 1500 psi. Refer to manufacturer's instructions accompanying the material for specific mix design.

MAXXON CORP — Types Maxxon Standard and Maxxon High Strength

Floor Mat Materials* — (Optional) — Floor mat material loose laid over the subfloor. Refer to manufacturer's instructions regarding the minimum thickness of floor topping over each floor mat material.

MAXXON CORP — Type Encapsulated Sound Mat.

Floor Mat Reinforcement — (Optional) - Refer to manufacturer's instructions regarding minimum thickness of floor topping for use with floor mat reinforcement.

Metal Lath — (Optional) — 3/8 in. expanded galvanized steel diamond mesh, 3.4 lbs/sq yd loose laid over the floor mat material.

Fiber Glass Reinforcement - (Optional, Not Shown) - 0.015 in. thick PVC coated non-woven fiberglass mesh, 0.368 lbs/sq yd loose laid over the floor mat material.

System No. 6

Subflooring — Min 23/32 in. thick T & G wood structural panels, min grade "Underlayment" or "Single-Floor". Face grain of plywood or strength axis of panel to be perpendicular to the trusses with end joints staggered 4 ft. Plywood or panels secured to trusses with construction adhesive and No. 6d cement coated nails spaced 12 in. OC along each truss. Adhesive applied as 3/8 in. diam bead to top chord of trusses and grooved edges of plywood or panel.

Finish Flooring — Floor Topping Mixture* — Min 3/4 in. thickness of floor topping mixture having a min compressive strength of 1000 psi. Refer to manufacturer's instructions accompanying the material for specific mix design.

FORMULATED MATERIALS LLC — Types FR-25, FR-30, and SiteMix

Floor Mat Material* — (Optional) Floor mat material nominal 2 - 9.5 mm thick loose laid over the subfloor. Floor topping shall be a min of 1 in.

FORMULATED MATERIALS LLC — Types M1, M2, M3, Elite, Duo, R1, and R2

System No. 7

Subflooring — Min 23/32 in. thick T & G wood structural panels, min grade "Underlayment" or "Single-Floor". Face grain of plywood or strength axis of panel to be perpendicular to the trusses with end joints staggered 4 ft. Plywood or panels secured to trusses with construction adhesive and No. 6d cement coated nails spaced 12 in. OC along each truss. Adhesive applied as 3/8 in. diam bead to top chord of trusses and grooved edges of plywood or panel.

Vapor Barrier — (Optional) — Nom 0.010 in. thick commercial asphalt saturated felt.

Finish Flooring — Floor Topping Mixture* — Min 3/4 in. thickness of floor topping mixture having a minimum compressive strength of 1800 psi. Refer to manufacturer's instructions accompanying the material for specific mix design.

UNITED STATES GYPSUM CO — Types LRK, HSLRK, CSD

USG MEXICO S A DE C V — Types LRK, HSLRK, CSD

Floor Mat Materials* — (Optional) — Floor mat material loose laid over the subfloor. Refer to manufacturer's instructions regarding the minimum thickness of floor topping over each floor mat material.

UNITED STATES GYPSUM CO — Types SAM, LEVELROCK® Brand Sound Reduction Board, LEVELROCK® Brand Floor Underlayment SRM-25

Alternate Floor Mat Materials* — (Optional) — Nom 3/8 in. thick floor mat material loose laid over the subfloor.

GRASSWORX L L C — Type SC50

System No. 8

Subflooring — Min 15/32 in. thick wood structural panels, min grade "C-D" or "Sheathing". Face grain of plywood or strength axis of panels to be perpendicular to the joists with joints staggered.

Vapor Barrier — (Optional) — Commercial asphalt saturated felt, 0.030 in. thick.

Vapor Barrier — (Optional) — Nom 0.010 in. thick commercial rosin-sized building paper.

Finish Flooring* — Min 3/4 in. thickness of any Floor Topping Mixture bearing the UL Classification Marking as to Fire Resistance. See Floor- and Roof-Topping Mixtures (CCOX) category for names of Classified Companies.

Floor Mat Materials* — (Optional) — Nom. 1/4 in. thick loose laid over the subfloor. Floor topping thickness shall be a minimum of 3/4 in.

KEENE BUILDING PRODUCTS CO INC — Type Quiet Qurl 55/025 and Quiet Qurl 55/025 N

Alternate Floor Mat Materials* — (Optional) — Floor mat material Nom. 3/8 in. thick loose laid over the subfloor. Floor topping thickness shall be a minimum of 1 in.

KEENE BUILDING PRODUCTS CO INC — Type Quiet Qurl 60/040 and Quiet Qurl 60/040 N

Alternate Floor Mat Materials* — (Optional) — Floor mat material Nom. 3/4 in. thick loose laid over the subfloor. Floor topping thickness shall be a minimum of 1-1/2 in.

KEENE BUILDING PRODUCTS CO INC — Type Quiet Qurl 65/075, Quiet Qurl 65/075 N

Alternate Floor Mat Materials* — (Optional) — Floor mat material Nom. 1/8 in. thick loose laid over the subfloor. Floor topping thickness shall be a minimum of 3/4 in.

KEENE BUILDING PRODUCTS CO INC — Type Quiet Qurl 52/013 and Quiet Qurl 52/013 N

Alternate Floor Mat Materials* — (Optional) — Floor mat material Nom. 1/4 in. entangled net core with a compressible fabric attached to the bottom loose laid over the subfloor. Floor topping thickness shall be a minimum of 1 in.

KEENE BUILDING PRODUCTS CO INC — Quiet Qurl 55/025 MT and Quiet Qurl 55/025 N MT

System No. 9

Subflooring — Min 23/32 in. thick T & G wood structural panels, min grade "Underlayment" or "Single-Floor". Face grain of plywood or strength axis of panel to be perpendicular to the trusses with end joints staggered 4 ft. Plywood or panels secured to trusses with construction adhesive and No. 6d cement coated nails spaced 12 in. OC along each truss. Adhesive applied as 3/8 in. diam bead to top chord of trusses and grooved edges of plywood or panel.

Finish Flooring — Floor Topping Mixture* — Min 3/4 in. thickness of floor topping mixture having a min compressive strength of 1000 psi. Refer to manufacturer's instructions accompanying the material for specific mix design.

ARCOSA SPECIALTY MATERIALS — AccuCrete® Types NexGen, Green, Prime and PrePour, AccuRadiant®, AccuLevel® Types G40, G50 and SD30

Floor Mat Material* — (Optional) — Floor mat material nominal 2 - 9.5 mm thick loose laid over the subfloor. Floor topping shall be a min of 1 in.

ARCOSA SPECIALTY MATERIALS/ACG MATERIALS — AccuQuiet® Types D13, D-18, D25, DX38, EM.125, EM.125S, EM.250, EM.250S, EM.375, EM.375S, EM.750, and EM.750S.

System No. 10

Subflooring — Min 23/32 in. thick T&G wood structural panels, min grade "Underlayment" or "Single-Floor". Face grain of plywood or strength axis of panels to be perpendicular to the trusses with end joints staggered 4 ft. Panels secured to trusses with construction adhesive and No. 6d ringed shank nails spaced 12 in. OC along each truss. Staples having equal or greater withdrawal and lateral resistance strength may be substituted for the 6d nails.

Gypsum Board* — One layer of nom 5/8 in. thick, 4 ft wide gypsum board, installed with long dimension perpendicular to joists. Gypsum board secured with 1 in. long No. 6 Type W bugle head steel screws spaced 12 in. OC and located a min of 1-1/2 in. from side and end joints. The joints of the gypsum board are to be staggered a minimum of 12 inches from the joints of the subfloor.

GEORGIA-PACIFIC GYPSUM L L C — Type DS

Floor Mat Materials* — (As an alternate to the single layer gypsum board) — Floor mat material loose laid over the subfloor.

MAXXON CORP — Type Encapsulated Sound Mat.

Gypsum Board* — (For use when floor mat is used) — Two layers of nom 5/8 in. thick, 4 ft wide gypsum board, installed with long dimension perpendicular to joists on top of the floor mat material. Gypsum board secured to each other with 1 in. long No. 6 Type G bugle head steel screws spaced 12 in. OC and located a min of 1-1/2 in. from side and end joints. The joints of the gypsum board are to be staggered a minimum of 12 inches in between layers and from the joints of the subfloor.

GEORGIA-PACIFIC GYPSUM L L C — Type DS

System No. 11

Subflooring — Min 23/32 in. thick T & G wood structural panels, min grade "Underlayment" or "Single-Floor". Face grain of plywood or strength axis of panel to be perpendicular to the trusses with end joints staggered 4 ft. Plywood or panels secured to trusses with construction adhesive and No. 6d cement coated nails spaced 12 in. OC along each truss. Adhesive applied as 3/8 in. diam bead to top chord of trusses and grooved edges of plywood or panel.

Finish Flooring — Floor Topping Mixture* — Min 3/4 in. thickness of floor topping mixture having a min compressive strength of 1000 psi. Refer to manufacturer's instructions accompanying the material for specific mix design.

DEPENDABLE LLC — GSL M3.4, GSL K2.6, GSL-CSD or GSL RH

Floor Mat Materials* — (Optional) — Nom. 1/4 in. thick loose laid over the subfloor. Floor topping thickness shall be a minimum of 3/4 in.

KEENE BUILDING PRODUCTS CO INC — Type Quiet Qurl 55/025 and Quiet Qurl 55/025 N

Alternate Floor Mat Materials* — (Optional) — Floor mat material Nom. 3/8 in. thick loose laid over the subfloor. Floor topping thickness shall be a minimum of 1 in.

KEENE BUILDING PRODUCTS CO INC — Type Quiet Qurl 60/040 and Quiet Qurl 60/040 N

Alternate Floor Mat Materials* — (Optional) — Floor mat material Nom. 3/4 in. thick loose laid over the subfloor. Floor topping thickness shall be a minimum of 1-1/2 in.

KEENE BUILDING PRODUCTS CO INC — Type Quiet Qurl 65/075, Quiet Qurl 65/075 N

Alternate Floor Mat Materials* — (Optional) — Floor mat material Nom. 1/8 in. thick loose laid over the subfloor. Floor topping thickness shall be a minimum of 3/4 in.

KEENE BUILDING PRODUCTS CO INC — Type Quiet Qurl 52/013 and Quiet Qurl 52/013 N

Alternate Floor Mat Materials* — (Optional) — Floor mat material Nom. 1/4 in. entangled net core with a compressible fabric attached to the bottom loose laid over the subfloor. Floor topping thickness shall be a minimum of 1 in.

KEENE BUILDING PRODUCTS CO INC — Quiet Qurl 55/025 MT and Quiet Qurl 55/025 N MT

System No. 12

Subflooring — Min 23/32 in. thick T & G wood structural panels, min grade "Underlayment" or "Single-Floor". Face grain of plywood or strength axis of panel to be perpendicular to the trusses with end joints staggered 4 ft. Plywood or panels secured to trusses with construction adhesive and No. 6d cement coated nails spaced 12 in. OC along each truss. Adhesive applied as 3/8 in. diam bead to top chord of trusses and grooved edges of plywood or panel.

Finish Flooring - Floor Topping Mixture* — Min 1 in. thickness of floor topping mixture having a min compressive strength of 4500 psi. Refer to manufacturer's instructions accompanying the material for specific mix design.

SIKA DEUTSCHLAND GMBH — Type SCHONOX AP Rapid Plus

System No. 13

Subflooring — Min 23/32 in. thick T & G wood structural panels, min grade "Underlayment" or "Single-Floor". Face grain of plywood or strength axis of panel to be perpendicular to the trusses with end joints staggered 4 ft. Plywood or panels secured to trusses with construction adhesive and No. 6d cement coated nails spaced 12 in. OC along each truss. Adhesive applied as 3/8 in. diam bead to top chord of trusses and grooved edges of plywood or panel.

Vapor Barrier — (Optional) - Commercial asphalt saturated felt, 0.030 in. thick.

Vapor Barrier — (Optional) - Nom 0.010 in. thick commercial rosin-sized building paper.

Finish Flooring - Floor Topping Mixture* — Min 3/4 in. thickness of any Floor Topping Mixture bearing the UL Classification Marking as to Fire Resistance. See Floor- and Roof-Topping Mixtures (CCOX) category for names of Classified Companies.

Floor Mat Materials* — (Optional, Not Shown) - Floor mat material loose laid over the subfloor. Refer to manufacturer's instructions regarding the minimum thickness of floor topping over each floor mat material.

LOW & BONAR INC — EnkaSonic® by Colbond a member of the Low & Bonar group Types 125, 250, 250 Plus, 400, 400 Plus, 750, and 750 Plus.

Floor Mat Reinforcement — (Optional) - Refer to manufacturer's instructions regarding minimum thickness of floor topping for use with floor mat reinforcement.

Metal Lath — (Optional) — Expanded steel diamond mesh, 2.5 lb / sq yd loose laid over floor mat material.

Fiberglass Mesh Reinforcement — (Optional) — Coated non-woven glass fiber mesh grid loose laid over floor mat material.

2. **Trusses** — Parallel chord trusses spaced a max 24 in. OC fabricated from nom 2 by 4 in. lumber with lumber orientated either vertically (2A) or horizontally (2B). Min truss depth is 12 in. Truss members secured together with No. 20 MSG galv steel truss plates. Plates include 5/16 in. long teeth projecting perpendicular to the plane of the plate. The teeth are in pairs facing each other made from the same punch creating a split tooth type plate. Each tooth has a chisel point on its outside edge, with these points being diagonally opposite from each other for each pair. The top half of each tooth has a twist for stiffness. The pairs are repeated on approx 7/8 in. centers with four rows of teeth per inch of plate width.

3. **Gypsum Board*** — Two layers of 1/2 in. thick, 4 ft wide gypsum board installed with long dimension perpendicular to trusses with end joints located under bottom of trusses. End joints in adjacent rows shall be staggered on adjacent joists. Base layer secured with 1-1/4 in. long Type S bugle head steel screws spaced 24 in. OC and located a min 1-1/2 in. from side joints. Outer layer secured to trusses through inner layer with 1-7/8 in. Type S bugle head steel screws spaced 12 in. OC. All joints in outer layer offset 24 in. from inner layer joints. When optional Steel Framing Members (Item 4, 4A) are used, sheets installed with long dimensions parallel with joists. Base layer attached to the furring channels using 1 in. long Type S bugle head steel screws spaced 12 in. OC in the field of the board. Butted end joints shall be staggered min 2 ft within the assembly, and occur midway between the continuous furring channels. At the butted end joints, each end of each gypsum board shall be supported by a single length of furring channel equal to the width of the gypsum board plus 6 in. on each end. The two furring channels shall be spaced approximately 3-1/2 in. OC, and be attached to underside of the joist with one clip at each end of the channel. Screw spacing along the end joint shall be 8 in. OC. Outer layer attached to the furring channels using 1-5/8 in. long Type S bugle head steel screws spaced 8 in. OC at butted joints and 12 in. OC in the field. Butted end joints to be offset a min of 8 in. from base layer end joints. Butted side joints of outer layer to be offset min 18 in. from butted side joints of base layer. When **Steel Framing Members** (Item 4B) are used, base layer gypsum board is installed with long dimensions perpendicular to furring channels. Gypsum board secured to furring channels with nom 1 in. long Type S bugle-head steel screws spaced 8 in. OC in the field of the board. Gypsum board butted end joints shall be staggered minimum 48 in. and centered over main furring channels. At the gypsum board butt joints, each end of each gypsum board shall be supported by a single length of furring channel equal to the width of the gypsum board plus 3 in. on each end. The two support furring channels shall be spaced approximately 3 in. in from joint. Screw spacing along the gypsum board butt joint and along both additional channels shall be 8 in. OC. Additional screws shall be placed in the adjacent section of gypsum board into the aforementioned 3 in. extension of the extra butt joint channels as well as into the main channel that runs between. Butt joint furring channels shall be attached with one RESILMOUNT Sound Isolation Clip at each end of the channel. Face layer secured as described above. When **Steel Framing Members** (Item 4C) are used, nom 5/8 in. thick, 4 ft wide gypsum board, installed as described in Item 3. Adjacent butt joints staggered minimum 48 in. OC.

When **Steel Framing Members** (Item 4D) are used, nom 5/8 in. thick, 4 ft wide gypsum board, installed as described in Item 3. Butt joints staggered minimum 24 in. OC.

AMERICAN GYPSUM CO — Types AG-C

CABOT MANUFACTURING ULC — Type C

CERTAINTEED GYPSUM INC — Type C

CGC INC — Types C, IP-X2, IPC-AR

CERTAINTEED GYPSUM INC — Type LGFC-C/A

GEORGIA-PACIFIC GYPSUM L L C — Types 5, DAPC, TG-C

NATIONAL GYPSUM CO — Types FSK-C, FSW-C

PABCO BUILDING PRODUCTS L L C, DBA PABCO GYPSUM — Type PG-C

PANEL REY S A — Type PRC

THAI GYPSUM PRODUCTS PCL — Type C

UNITED STATES GYPSUM CO — Types C, IP-X2, IPC-AR

USG BORAL DRYWALL SFZ LLC — Type C

USG MEXICO S A DE C V — Types C, IP-X2, IPC-AR

3A. **Gypsum Board*** — (Not Shown) - Two layers of 5/8 in. thick, 4 ft wide gypsum board installed as described in Item 3 with screws spaced a max. 8 in. OC.

CGC INC — Type ULIX

UNITED STATES GYPSUM CO — Type ULIX

4. **Steel Framing Members*** — (Optional, Not Shown) — As an option, furring channels and **Steel Framing Members** as described below may be used to secure the gypsum board:

a. **Furring Channels** — Formed of No. 25 MSG galv steel, 2-9/16 in. or 2-23/32 in. wide by 7/8 in. deep, spaced 24 in. OC perpendicular to trusses. Channels secured to trusses as described in Item b. Ends of adjoining channels overlapped 6 in. and tied together with double strand of No. 18 SWG galv steel wire near each end of overlap.

b. **Steel Framing Members*** — Used to attach furring channels (Item a) to trusses (Item 2). Clips spaced 48 in. OC, and secured to alternating trusses with No. 8 x 2-1/2 in. coarse drywall screw through the center grommet. Furring channels are friction fitted into clips. RSIC-1 clip for use with 2-9/16 in. wide furring channels. RSIC-1 (2.75) clip for use with 2-23/32 in. wide furring channels. Adjoining channels are overlapped as described in Item a. As an alternate, ends of adjoining channels may be overlapped 6 in. and secured together with two self-tapping No. 6 framing screws, min 7/16 in. long at the midpoint of the overlap, with one screw on each flange of the channel. Additional clips required to hold furring channel that supports the gypsum board butt joints, as described in Item 3.

PAC INTERNATIONAL L L C — Types RSIC-1, RSIC-1 (2.75)

4A. **Steel Framing Members** — (Optional, Not Shown) — As an option, furring channels and Steel Framing Members as described below may be used to secure the gypsum board:

a. **Furring Channels** — Formed of No. 25 MSG galv steel, 2-3/8 in. wide by 7/8 in. deep, spaced 24 in. OC perpendicular to trusses. Channels secured to trusses as described in Item b. Ends of adjoining channels overlapped 6 in. and tied together with double strand of No. 18 SWG galv steel wire near each end of overlap.

b. **Steel Framing Members*** — Used to attach furring channels (Item a) to trusses (Item 2). Clips spaced 48 in. OC, and secured to alternating trusses with No. 8 x 2-1/2 in. coarse drywall screw through the center grommet. Furring channels are friction fitted into clips. Adjoining channels are overlapped as described in Item a. As an alternate, ends of adjoining channels may be overlapped 6 in. and secured together with two self-tapping No. 6 framing screws, min 7/16 in. long at the midpoint of the overlap, with one screw on each flange of the channel. Additional clips required to hold furring channel that supports the gypsum board butt joints, as described in Item 3.

PLITEQ INC — Type GENIECLIP

4B. **Alternate Steel Framing Members*** — (Not Shown) — As an alternate to items 4 and 4A, furring channels and Steel Framing Members as described below.

a. **Furring Channels** — Formed of No. 25 MSG galv steel, 2-5/8 in. wide by 7/8 in deep, spaced 24 in OC, perpendicular to trusses. Channels secured to trusses as described in Item b.

b. **Steel Framing Members*** — Used to attach furring channels (Item a) to trusses (Item 2). Clips spaced at 48" OC and secured to the bottom of the joists with one 2 in. Coarse Drywall Screw with 1 in. diam washer through the center hole. Furring channels are then friction fitted into clips. Ends of channels are overlapped 6" and tied together with double strand of No. 18 AWG galvanized steel wire. Additional clips are required to hold the Gypsum Butt joints as described in item 3.

STUDCO BUILDING SYSTEMS — RESILMOUNT Sound Isolation Clips - Type A237R

4C. **Steel Framing Members*** — (Optional, Not Shown) — As an alternate to Item 4.

a. **Furring Channels** — Formed of No. 25 MSG galv steel, nominal 2-1/2 in. wide by 7/8 in. deep, spaced 24 in. OC, perpendicular to the trusses. Channels secured to Cold Rolled Channels at every intersection with a 3/4 in. TEK screw through each furring channel leg. Ends of adjoining channels overlapped 12 in. and fastened together with two double strand No. 18 SWG galv steel wire ties, one at each end of overlap, or with two 3/4 in. TEK screws in each leg of the overlap section. Two furring channels positioned 3 in. OC, 1-1/2 in. on each side of gypsum board (Item 3) end joints, each extending a min of 6 in. beyond both side edges of the board.

b. **Cold Rolled Channels** — 1-1/2 in. by 1/2 in., formed from No. 16 ga. galv steel, positioned vertically and parallel to trusses, friction-fitted into the channel caddy on the Steel Framing Members (Item 4Cd) and secured with two 3/4 in. TEK screws. Adjoining lengths of cold rolled channels lapped min. 12 in. and secured along bottom legs with four 3/4 in. TEK screws and wire-tied together with two double strand 18 SWG galv steel wire ties, one at each end of overlap.

c. **Blocking** — Where truss design does not permit direct, full contact of the hanger bracket, a piece of nominal 2 by 4 in. lumber (blocking), min. 12 in. long to permit full contact of the hanger bracket, to be secured vertically to the side of the trusses at the top and bottom of the blocking at each Steel Framing Member (Item 4Cd) location with 16d nails or minimum 2-1/2 in. screws.

d. **Steel Framing Members*** — Spaced 48 in. OC. max along truss, and secured to the truss on alternating trusses with two, #10 x 1-1/2 in. screws through mounting holes on the hanger bracket.

PAC INTERNATIONAL L L C — Type RSIC-SI-CRC EZ Clip

4D. **Steel Framing Members*** — (Not Shown) — As an alternate to Item 4.

a. **Furring Channels** — Formed of No. 25 MSG galv steel, nominal 2-1/2 in. wide by 7/8 in. deep, spaced 24 in. OC perpendicular to trusses and friction fit into Steel Framing Members (Item 4Dc). Ends of adjoining channels overlapped 6 in. and tied together with double strand of No. 18 SWG galv steel wire near each end of overlap or with two TEK screws along each leg of the 6 in. overlap. Two furring channels positioned 6 in. OC, 3 in. on each side of gypsum board (Item 3) end joints. Butt joint channels held in place by strong back channels placed upside down, on top of, and running perpendicular to primary furring channels, extending 6 in. longer than length of gypsum side joint. Strong back channels spaced maximum 48 in. OC. Strong back channels secured to every intersection of primary furring channels with four 7/16 in. pan head screws, two along each of the legs at intersections. Butt joint channels run perpendicular to strong back channels and shall be minimum 6 in. longer than length of joint, secured to strong back channels with 7/16 in. pan head screws, two along each of the legs at intersection with strong back channels.

b. **Blocking** — Where truss design does not permit direct, full contact of the hanger bracket, a piece of nominal 2 by 4 in. lumber (blocking), min. 12 in. long to permit full contact of the hanger bracket, to be secured vertically to the side of the trusses at the top and bottom of the blocking at each Steel Framing Member (Item 4Dc) location with 16d nails or minimum 2-1/2 in. screws.

c. **Steel Framing Members*** — Used to attach furring channels (Item 4Da) to trusses. Clips spaced 48 in. OC and secured along truss webs at each furring channel intersection with min. 3/4 in. long self-drilling No. 10-16 TEK screws through each of the provided hole locations. Furring channels are friction fitted into clips.

PAC INTERNATIONAL L L C — Type RSIC-S1-1 Ultra

5. **Finishing System** — (Not Shown) — Vinyl, dry or premixed joint compound, applied in two coats to joints and screw-heads. Nom 2 in. wide paper tape embedded in first layer of compound over all joints. As an alternate, nom 3/32 in. thick veneer plaster may be applied to the entire surface of gypsum board.

*** Indicates such products shall bear the UL or cUL Certification Mark for jurisdictions employing the UL or cUL Certification (such as Canada), respectively.**

Last Updated on 2021-10-06

La presencia del nombre de una empresa o producto en esta base de datos no garantiza por sí misma que los productos así identificados hayan sido fabricados bajo el servicio de seguimiento de UL. Solo aquellos productos que lleven la marca UL deben considerarse como certificados y garantizados bajo el servicio de seguimiento de UL. Busque siempre la marca en el producto.

UL permite la reproducción del material contenido en el directorio de certificación en línea sujeta a las siguientes condiciones: 1. La información de la guía, las ensamblajes, las construcciones, los diseños, los sistemas y/o certificaciones (archivos) deben presentarse en su totalidad y de forma no engañosa, sin ninguna manipulación en los datos (o dibujos). 2. Debe aparecer la declaración "Reimpreso desde el directorio de certificaciones en línea con permiso de UL" junto al material extraído. Además, el material reimpreso debe incluir una nota de derechos de autor en el siguiente formato: "© 2021 UL LLC"