

BXUV.L525

PANEL REY®
Drywall Solutions

Design/System/Construction/Assembly Usage Disclaimer

- Authorities Having Jurisdiction should be consulted in all cases as to the particular requirements covering the installation and use of UL Certified products, equipment, system, devices, and materials.
- Authorities Having Jurisdiction should be consulted before construction.
- Fire resistance assemblies and products are developed by the design submitter and have been investigated by UL for compliance with applicable requirements. The published information cannot always address every construction nuance encountered in the field.
- When field issues arise, it is recommended the first contact for assistance be the technical service staff provided by the product manufacturer noted for the design. Users of fire resistance assemblies are advised to consult the general Guide Information for each product category and each group of assemblies. The Guide Information includes specifics concerning alternate materials and alternate methods of construction.
- Only products which bear UL's Mark are considered Certified.

BXUV - Fire Resistance Ratings - ANSI/UL 263 Certified for United States

BXUV7 - Fire Resistance Ratings - CAN/ULC-S101 Certified for Canada

Design No. L525

Unrestrained Assembly Rating — 1 Hr.
Finish Rating — 21 Min.

This design was evaluated using a load design method other than the Limit States Design Method (e.g., Working Stress Design Method). For jurisdictions employing the Limit States Design Method, such as Canada, a load restriction factor shall be used — See Guide [BXUV](#) or [BXUV7](#)

*** Indicates such products shall bear the UL or cUL Certification Mark for jurisdictions employing the UL or cUL Certification (such as Canada), respectively.**

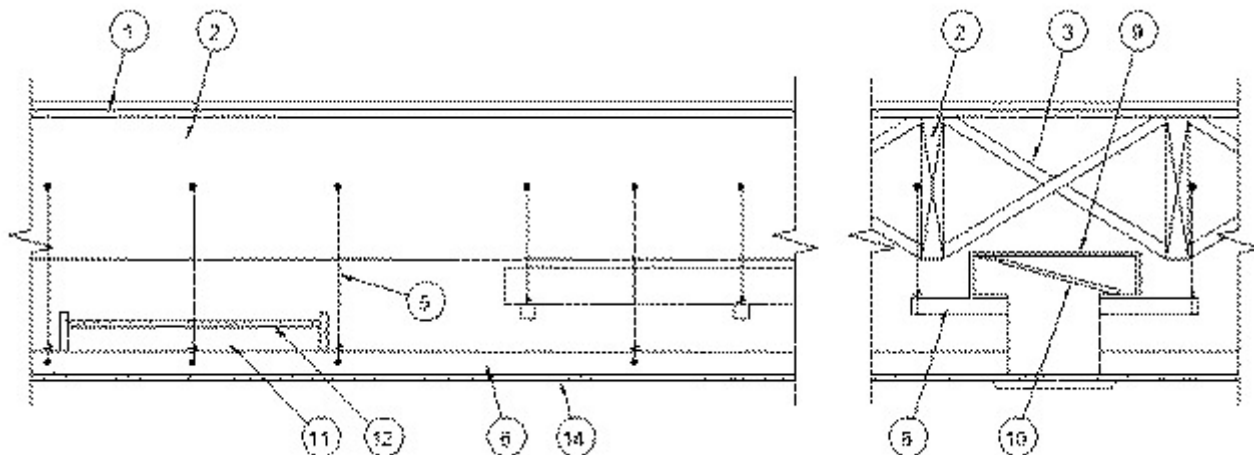

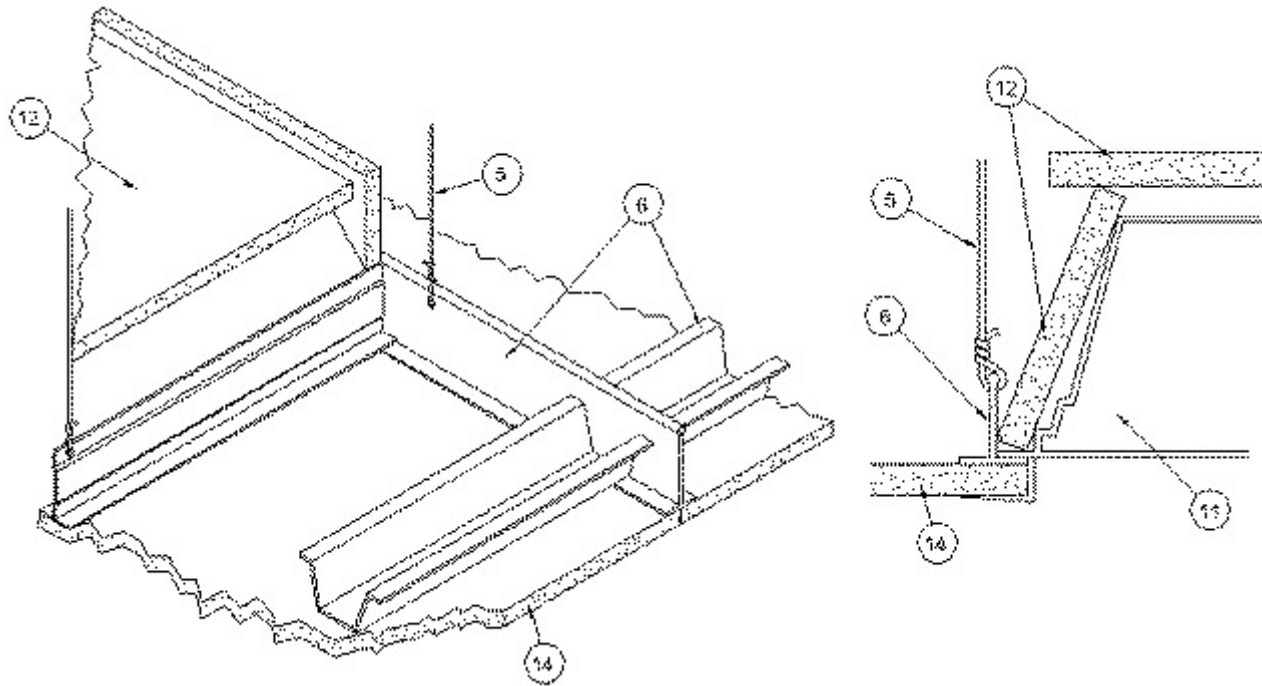

1. Flooring System — The flooring system shall consist of one of the following:

System No. 1

Subflooring — Min 1 by 6 in. T & G lumber fastened diagonally to joists, or min 15/32 in. thick wood structural panels, min grade "C-D" or "Sheathing". Face grain of plywood or strength axis of panels to be perpendicular to joists with joints staggered.

Vapor Barrier — (Optional) - Nom 0.010 in. thick commercial rosin-sized building paper.

Finish Flooring — Min 1 by 4 in. T&G lumber installed perpendicular to trusses, or min 19/32 in. thick wood structural panels, min grade "Underlayment" or "Single-Floor". Face grain of plywood or strength axis of panels to be perpendicular to joists with joints staggered.

System No. 2

Subflooring — Min 1 by 6 in. T & G lumber fastened diagonally to joists, or min 15/32 in. thick wood structural panels, min grade "C-D" or "Sheathing". Face grain of plywood or strength axis of panels to be perpendicular to joists with joints staggered.

Vapor Barrier — (Optional) — Nom 0.010 in. thick commercial rosin-sized building paper.

Floor Mat Materials* — (Optional) — Floor mat material nom 5/64 in. (2 mm) thick adhered to subfloor with Hacker Floor Primer. Primer to be applied to the surface of the mat prior to the placement of a min 1-1/4 in. of floor-topping mixture.

HACKER INDUSTRIES INC — Type Hacker Sound-Mat.

Alternate Floor Mat Materials — (Optional) — Floor mat material nom 1/4 in. (6 mm) thick adhered to subfloor with Hacker Floor Primer. Primer to be applied to the surface of the mat prior to the placement of a min 1-1/4 in. (32 mm) of floor-topping mixture.

HACKER INDUSTRIES INC — Type Hacker Sound-Mat II

Alternate Floor Mat Materials — (Optional) — Floor mat material nom 1/8 in. (3 mm) thick loose laid over the subfloor. Floor topping thickness shall be a min of 1 in. (25 mm)

HACKER INDUSTRIES INC — FIRM-FILL SCM 125

Alternate Floor Mat Materials — (Optional) — Floor mat material nom 1/4 in. (6 mm) thick loose laid over the subfloor. Floor topping thickness shall be a min of 1 in. (25 mm)

HACKER INDUSTRIES INC — Type FIRM-FILL SCM 250, Quiet Qurl 55/025

Alternate Floor Mat Materials — (Optional) — Floor mat material nom 3/8 in. (10 mm) thick loose laid over the subfloor. Floor topping thickness shall be a min of 1-1/4 in. (32 mm)

HACKER INDUSTRIES INC — FIRM-FILL SCM 400, Quiet Qurl 60/040

Alternate Floor Mat Materials — (Optional) — Floor mat material nom 3/4 in. (19 mm) thick loose laid over the subfloor. Floor topping thickness shall be a min of 1-1/2 in. (38 mm)

HACKER INDUSTRIES INC — Type FIRM-FILL SCM 750, Quiet Qurl 65/075

Metal Lath (Optional) — For use with 3/8 in. (10 mm) floor mat materials, 3/8 in. expanded steel diamond mesh, 3.4 lbs/sq yd placed over the floor mat material. Hacker Floor Primer to be applied prior to the placement of the metal lath. When metal lath is used, floor topping thickness a nom 1-1/4 in. over the floor mat.

Finish Flooring — Floor Topping Mixture* — Min 1 in. thickness of floor topping mixture having a min compressive strength of 1100 psi. Mixture shall consist of 6.8 gal of water to 80 lbs of floor topping mixture to 1.9 cu ft of sand.

HACKER INDUSTRIES INC — Firm-Fill Gypsum Concrete, Firm-Fill 2010, Firm-Fill 3310, Firm-Fill 4010, Firm-Fill High Strength, Gyp-Span Radiant

System No. 3

Subflooring — Min 15/32 in. thick wood structural panels, min grade "C-D" or "Sheathing". Face grain of plywood or strength axis of panels to be perpendicular to joists with joints staggered.

Vapor Barrier — (Optional) — Nom 0.010 in. thick commercial asphalt saturated felt.

Finish Flooring — Floor Topping Mixture* — Min 3/4 in. thickness of floor topping mixture having a minimum compressive strength of 1800 psi. Refer to manufacturer's instructions accompanying the material for specific mix design.

UNITED STATES GYPSUM CO — Types LRK, HSLRK, CSD

USG MEXICO S A DE C V — Types LRK, HSLRK, CSD

Floor Mat Materials* — (Optional) — Floor mat material loose laid over the subfloor. Refer to manufacturer's instructions regarding the minimum thickness of floor topping over each floor mat material.

UNITED STATES GYPSUM CO — Types SAM, LEVELROCK® Brand Sound Reduction Board, LEVELROCK® Brand Floor Underlayment SRM-25

Alternate Floor Mat Materials* — (Optional) — Nom 3/8 in. thick floor mat material loose laid over the subfloor. Floor topping thickness shall be as specified under Floor Topping Mixture.

GRASSWORX L L C — Type SC50

System No. 4

Subflooring — Min 15/32 in. thick wood structural panels, min grade "C-D" or "Sheathing". Face grain of plywood or strength axis of panels to be perpendicular to joists with joints staggered.

Vapor Barrier — (Optional) — Nom 0.030 in. thick commercial asphalt saturated felt.

Finish Flooring - Floor Topping Mixture* — Min 3/4 in. thickness of floor topping mixture having a min compressive strength of 1000 psi. Mixture shall consist of 5 to 8 gal of water to 80 lbs of floor topping mixture to 2.1 cu ft of sand.

ULTRA QUIET FLOORS — Types UQF-A, UQF-Super Blend, UQF-Plus 2000

System No. 5

Subflooring — Min 19/32 in. thick wood structural panels, min grade "C-D" or "Sheathing". Face grain of plywood or strength axis of panels to be perpendicular to joists with joints staggered.

Vapor Barrier — (Optional) — Nom 0.030 in. thick commercial asphalt saturated felt.

Finish Flooring — Floor Topping Mixture* — Min 3/4 in. thickness of floor topping mixture having a minimum compressive strength of 1500 psi. Refer to manufacturer's instructions accompanying the material for specific mix design.

MAXXON CORP — Types Maxxon Standard and Maxxon High Strength

Floor Mat Materials* — (Optional) — Floor mat material loose laid over the subfloor. Refer to manufacturer's instructions regarding the minimum thickness of floor topping over each floor mat material.

MAXXON CORP — Type Top Encapsulated Sound Mat.

Floor Mat Reinforcement — (Optional) - Refer to manufacturer's instructions regarding minimum thickness of floor topping for use with floor mat reinforcement.

Metal Lath — (Optional) — 3/8 in. expanded galvanized steel diamond mesh, 3.4 lbs/sq yd loose laid over the floor mat material.

Fiber Glass Reinforcement - (Optional, Not Shown) - 0.015 in. thick PVC coated non-woven fiberglass mesh, 0.368 lbs/sq yd loose laid over the floor mat material.

System No. 6

Subflooring — Min 15/32 in. thick wood structural panels, min grade C-D or Sheathing. Face grain of plywood or strength axis of panels to be perpendicular to joists with joints staggered.

Vapor Barrier — (Optional) Nom 0.030 in. thick commercial asphalt saturated felt.

Finish Flooring — Floor Topping Mixture* — Min 3/4 in. thickness of floor topping mixture having a minimum compressive strength of 1500 psi. Refer to manufacturer's instructions accompanying the material for specific mix design.

FORMULATED MATERIALS LLC — Types FR-25, FR-30, and SiteMix

Alternate Floor Mat Material* — (Optional) Floor mat material nominal 2 - 9.5 mm thick loose laid over the subfloor. Floor topping thickness shall be a minimum of 3/4 in.

FORMULATED MATERIALS LLC — Types M1, M2, M3, Elite, Duo, R1, and R2

System No. 7

Subflooring — Min 1 by 6 in. T & G lumber fastened diagonally to joists, or min 15/32 in. thick wood structural panels, min grade "C-D" or "Sheathing". Face grain of plywood or strength axis of panels to be perpendicular to joists with joints staggered.

Vapor Barrier — (Optional) — Nom 0.010 in. thick commercial rosin-sized building paper.

Finish Floor - Mineral and Fiber Board* — Min 1/2 in. thick, supplied in sizes ranging from 3 ft by 4 ft to 8 ft by 12 ft. All joints to be staggered a min of 12 in. with adjacent sub-floor joints.

HOMASOTE CO — Type 440-32 Mineral and Fiber Board

System No. 8

Subflooring — Min 15/32 in. thick wood structural panels, min grade "C-D" or "Sheathing". Face grain of plywood or strength axis of panels to be perpendicular to joists with joints staggered.

Vapor Barrier — (Optional) — Nom 0.030 in. thick commercial asphalt saturated felt.

Finish Flooring - Floor Topping Mixture* — Min 3/4 or 1 in. thickness of floor topping mixture for 19/32 or 15/32 in. thick wood structural panels respectively, having a min compressive strength of 1000 psi. Refer to manufacturer's instructions accompanying the material for specific mix design.

ARCOSA SPECIALTY MATERIALS — AccuCrete® Types NexGen, Green, Prime and PrePour, AccuRadiant®, AccuLevel® Types G40, G50 and SD30

Alternate Floor Mat Material* — (Optional) — Floor mat material nominal 2 - 9.5 mm thick loose laid over the subfloor. Floor topping shall be a min of 3/4 in. or 1 in. thickness of floor topping mixture for 19/32 or 15/32 in. thick wood structural panels respectively.

ARCOSA SPECIALTY MATERIALS — AccuQuiet® Types D13, D-18, D25, DX38, EM.125, EM.125S, EM.250, EM.250S, EM.375, EM.375S, EM.750, and EM.750S.

System No. 9

Subflooring — 15/32 or 19/32 in. thick wood structural panels, min. grade "C-D" or "Sheathing". Face grain of plywood or strength axis of panels to be perpendicular to joists with joints staggered.

Vapor Barrier — (Optional) — Nom 0.030 in. thick commercial asphalt saturated felt.

Finish Flooring — Floor Topping Mixture* — Min 3/4 or 1 in. thickness of floor topping mixture for 19/32 or 15/32 in. thick wood structural panels respectively, having a min compressive strength of 2100 psi. Refer to manufacturer's instructions accompanying the material for specific mix design.

1. **Flooring System** — The flooring system shall consist of one of the following:

System No. 10

Subflooring — Min 15/32 in. thick wood structural panels, min grade "C-D" or "Sheathing". Face grain of plywood or strength axis of panels to be perpendicular to the joists with joints staggered.

Vapor Barrier — (Optional) — Commercial asphalt saturated felt, 0.030 in. thick.

Vapor Barrier — (Optional) — Nom 0.010 in. thick commercial rosin-sized building paper.

Finish Flooring* — Min 3/4 in. thickness of any Floor Topping Mixture bearing the UL Classification Marking as to Fire Resistance. See Floor- and Roof-Topping Mixtures (CCOX) category for names of Classified Companies.

Floor Mat Materials* — (Optional) — Nom. 1/4 in. thick loose laid over the subfloor. Floor topping thickness shall be a minimum of 3/4 in.

KEENE BUILDING PRODUCTS CO INC — Type Quiet Qurl 55/025 and Quiet Qurl 55/025 N

Alternate Floor Mat Materials* — (Optional) — Floor mat material Nom. 3/8 in. thick loose laid over the subfloor. Floor topping thickness shall be a minimum of 1 in.

KEENE BUILDING PRODUCTS CO INC — Type Quiet Qurl 60/040 and Quiet Qurl 60/040 N

Alternate Floor Mat Materials* — (Optional) — Floor mat material Nom. 3/4 in. thick loose laid over the subfloor. Floor topping thickness shall be a minimum of 1-1/2 in.

KEENE BUILDING PRODUCTS CO INC — Type Quiet Qurl 65/075, Quiet Qurl 65/075 N

Alternate Floor Mat Materials* — (Optional) — Floor mat material Nom. 1/8 in. thick loose laid over the subfloor. Floor topping thickness shall be a minimum of 3/4 in.

KEENE BUILDING PRODUCTS CO INC — Type Quiet Qurl 52/013 and Quiet Qurl 52/013 N

Alternate Floor Mat Materials* — (Optional) — Floor mat material Nom. 1/4 in. entangled net core with a compressible fabric attached to the bottom loose laid over the subfloor. Floor topping thickness shall be a minimum of 1 in.

KEENE BUILDING PRODUCTS CO INC — Quiet Qurl 55/025 MT and Quiet Qurl 55/025 N MT

System No. 11

Subflooring — Min 23/32 in. thick T&G wood structural panels, min grade "Underlayment" or "Single-Floor". Face grain of plywood or strength axis of panels to be perpendicular to the trusses with end joints staggered 4 ft. Panels secured to trusses with construction adhesive and No. 6d ringed shank nails spaced 12 in. OC along each truss. Staples having equal or greater withdrawal and lateral resistance strength may be substituted for the 6d nails.

Gypsum Board* — One layer of nom 5/8 in. thick, 4 ft wide gypsum board, installed with long dimension perpendicular to joists. Gypsum board secured with 1 in. long No. 6 Type W bugle head steel screws spaced 12 in. OC and located a min of 1-1/2 in. from side and end joints. The joints of the gypsum board are to be staggered a minimum of 12 inches from the joints of the subfloor.

GEORGIA-PACIFIC GYPSUM L L C — Type DS

Floor Mat Materials* — (As an alternate to the single layer gypsum board) — Floor mat material loose laid over the subfloor.

MAXXON CORP — Type Encapsulated Sound Mat.

Gypsum Board* — (For use when floor mat is used) Two layers of nom 5/8 in. thick, 4 ft wide gypsum board, installed with long dimension perpendicular to joists on top of the floor mat material. Gypsum board secured to each other with 1 in. long No. 6 Type G bugle head steel screws spaced 12 in. OC and located a min of 1-1/2 in. from side and end joints. The joints of the gypsum board are to be staggered a minimum

of 12 inches in between layers and from the joints of the subfloor.

GEORGIA-PACIFIC GYPSUM L L C — Type DS

System No. 12

Subflooring — Min 15/32 in. thick wood structural panels, min grade "C-D" or "Sheathing". Face grain of plywood or strength axis of panels to be perpendicular to joists with joints staggered.

Vapor Barrier — (Optional) — Nom 0.030 in. thick commercial asphalt saturated felt.

Finish Flooring - Floor Topping Mixture* — Min 3/4 or 1 in. thickness of floor topping mixture for 19/32 or 15/32 in. thick wood structural panels respectively, having a min compressive strength of 1000 psi. Refer to manufacturer's instructions accompanying the material for specific mix design.

DEPENDABLE LLC — GSL M3.4, GSL K2.6, GSL-CSD and GSL RH

Floor Mat Materials* — (Optional) — Nom. 1/4 in. thick loose laid over the subfloor. Floor topping thickness shall be a minimum of 3/4 in.

KEENE BUILDING PRODUCTS CO INC — Type Quiet Qurl 55/025 and Quiet Qurl 55/025 N

Alternate Floor Mat Materials* — (Optional) — Floor mat material Nom. 3/8 in. thick loose laid over the subfloor. Floor topping thickness shall be a minimum of 1 in.

KEENE BUILDING PRODUCTS CO INC — Type Quiet Qurl 60/040 and Quiet Qurl 60/040 N

Alternate Floor Mat Materials* — (Optional) — Floor mat material Nom. 3/4 in. thick loose laid over the subfloor. Floor topping thickness shall be a minimum of 1-1/2 in.

KEENE BUILDING PRODUCTS CO INC — Type Quiet Qurl 65/075, Quiet Qurl 65/075 N

Alternate Floor Mat Materials* — (Optional) — Floor mat material Nom. 1/8 in. thick loose laid over the subfloor. Floor topping thickness shall be a minimum of 3/4 in.

KEENE BUILDING PRODUCTS CO INC — Type Quiet Qurl 52/013 and Quiet Qurl 52/013 N

Alternate Floor Mat Materials* — (Optional) — Floor mat material Nom. 1/4 in. entangled net core with a compressible fabric attached to the bottom loose laid over the subfloor. Floor topping thickness shall be a minimum of 1 in.

KEENE BUILDING PRODUCTS CO INC — Quiet Qurl 55/025 MT and Quiet Qurl 55/025 N MT

System No. 13

Subflooring — Min 1 by 6 in. T & G lumber fastened diagonally to joists, or min 15/32 in. thick wood structural panels, min grade "C-D" or "Sheathing". Face grain of plywood or strength axis of panels to be perpendicular to joists with joints staggered.

Finish Flooring* — Floor Topping Materials — Min 3/4 in. to 1-1/2 in. thickness of any Floor Topping Mixture bearing the UL Classification Marking as to Fire Resistance with a minimum compressive strength of 1500 psi.

See **Floor- and Roof-Topping Mixtures (CCOX)** category for names of Classified Companies.

Floor Mat Materials* — (Optional) — Floor mat material nom 1/8 in. to 3/4 in. thick. Loose laid over the subfloor. When used, Acousti-flor CSM (crack suppression mat) is loose laid over the floor mat material. Floor topping material thickness is dependent on thickness of floor mat used.

WALFLOR INDUSTRIES INC — Type Acousti-flor, Acousti-flor CSM. Floor topping thickness depends on products used as follows:

Acousti-flor (1/8 in. thick) - Floor topping thickness shall be a minimum of 3/4 in.

Acousti-flor (1/4 in. thick) - Floor topping thickness shall be a minimum of 1 in.

Acousti-flor (3/8 in. thick) - Floor topping thickness shall be a minimum of 1 in.

Acousti-flor (3/4 in. thick) - Floor topping thickness shall be a minimum of 1-1/2 in.

Metal Lath — (Optional) — Expanded steel diamond mesh, 2.5 lb / sq yd loose laid over floor mat material.

Fiberglass Mesh Reinforcement — (Optional) — Coated non-woven glass fiber mesh grid loose laid over floor mat material.

System No. 14

Subflooring — Min 1 by 6 in. T & G lumber fastened diagonally to joists, or min 15/32 in. thick wood structural panels, min grade "C-D" or "Sheathing". Face grain of plywood or strength axis of panels to be perpendicular to joists with joints staggered.

Finish Flooring - Floor Topping Mixture* — Min 1 in. thickness of floor topping mixture having a min compressive strength of 4500 psi. Refer to manufacturer's instructions accompanying the material for specific mix design.

SIKA DEUTSCHLAND GMBH — Type SCHONOX AP Rapid Plus

System No. 15

Subflooring — Min 1 by 6 in. T & G lumber fastened diagonally to joists, or min 15/32 in. thick wood structural panels, min grade "C-D" or "Sheathing". Face grain of plywood or strength axis of panels to be perpendicular to joists with joints staggered.

Vapor Barrier — (Optional) - Commercial asphalt saturated felt, 0.030 in. thick.

Vapor Barrier — (Optional) - Nom 0.010 in. thick commercial rosin-sized building paper.

Finish Flooring - Floor Topping Mixture* — Min 3/4 in. thickness of any Floor Topping Mixture bearing the UL Classification Marking as to Fire Resistance. See Floor- and Roof-Topping Mixtures (CCOX) category for names of Classified Companies.

Floor Mat Materials* — (Optional, Not Shown) - Floor mat material loose laid over the subfloor. Refer to manufacturer's instructions regarding the minimum thickness of floor topping over each floor mat material.

LOW & BONAR INC — EnkaSonic® by Colbond a member of the Low & Bonar group Types 125, 250, 250 Plus, 400, 400 Plus, 750, and 750 Plus.

Floor Mat Reinforcement — (Optional) - Refer to manufacturer's instructions regarding minimum thickness of floor topping for use with floor mat reinforcement.

Metal Lath — (Optional) — Expanded steel diamond mesh, 2.5 lb / sq yd loose laid over floor mat material.

Fiberglass Mesh Reinforcement — (Optional) — Coated non-woven glass fiber mesh grid loose laid over floor mat material.

2. **Wood Joists** — Min 2 by 10, spaced 16 in. OC and effectively fireblocked in accordance with local codes.

3. **Cross Bridging** — Min 1 by 3 in., or min 2 by 10 solid blocking.

4. **Wood Hanger Block** — (Not Shown) — Nom 2 by 4 in. installed between and perpendicular to wood joists, and centered 4-1/2 in. below subflooring. Secured to wood joists with two 16d nails at each end. Located as required to provide attachment provisions for hanger wire (Item 5).

5. **Hanger Wire** — No. 12 SWG galv steel wire. Hanger wires spaced max 48 in. OC along main runners and located at ends of main runners at walls and at corners and midspan along 4 ft sides of light fixtures. Hanger wires supported from 16d nails driven through wood joists 4-1/2 in. below subflooring and bent upward at both ends for positive support. Where hanger wire locations occur between joists, hanger wires shall be supported from wood hanger blocks.

6. **Steel Framing Members*** — Main runners, cross tees, cross channels and wall angle as listed below:

a. **Main Runners** — Nom 10 or 12 ft. long, 15/16 in. or 1-1/2 in. wide face, spaced 4 ft. OC.

b. **Cross Tees** — Nom 4 ft. long, 1-1/2 in. wide face or 15/16 in. wide face installed at sides of light fixtures (Item 11), installed perpendicular to the main runners, spaced 24 in. OC. When **Batts and Blankets*** (Item 13) are used, cross tees spaced 16 in. OC.

Additional cross tees or cross channels used at 8 in. from each side of butted gypsum board end joints. The cross tees or cross channels may be riveted or screw attached to the wall angle or channel to facilitate the ceiling installation. When NEMA Type F (Item 11B) light fixtures are used, nom 4ft long cross tees, 1-1/2 in wide face, installed perpendicular to main runners and spaced nom 50 in. O.C. Two nom 50 in. long cross tees, 1-1/2 inch wide face, spaced nom 14 in. O.C. to accommodate nom 1 by 2 ft or 1 by 4 ft NEMA Type F fixture or spaced 26 in. O.C. to accommodate nom 2 by 2 ft NEMA or 2 by 4 ft NEMA Type F fixture. When nom 2 by 2 ft NEMA Type F fixture is used, nom 26 in. long cross tees to be used to form nom 26 in. module at the center of the nom 50 in. long cross tees. Two additional nom 4 ft cross tees, 1-1/2 in. wide face are installed perpendicular to the main runners outside each end of fixture opening to support the end pieces of drywall fixture protection. Small cutoff pieces of cross tees were installed at the center of the nom 50 in. long cross tees and main runners by inserting the dip end into a cross tee slot on the main runner and securing the other end with a pop rivet to the nom 50 in. long cross tee.

c. **Cross Channels** — Nom 4 ft. long, installed perpendicular to main runners, spaced 24 in. OC. When **Batts and Blankets*** (Item 13) are used, cross channels spaced 16 in. OC.

d. **Wall Angle or Channel** — Painted or galv steel angle with 1 in. legs or 1-9/16 in. deep painted or galv steel channel with 1 in. legs attached to walls at perimeter of ceiling with fasteners 16 in. OC. to support steel framing member ends and for screw-attachment of the gypsum board.

CGC INC — Type DGL or RX

USG INTERIORS LLC — Type DGL or RX

6A. **Alternate Steel Framing Members*** — (Not Shown) — As an alternate to Item 6, nom 12 ft long main runners spaced 48 in. OC. Nom 4 ft long cross tees installed perpendicular to main runners and spaced 24 in. OC. Additional cross tees located 8 in. from and on both sides of each gypsum board end joint and each recessed light fixture.

ROXUL USA INC. D/B/A ROCKFON — Types 650, 650C

6B. **Alternate Steel Framing Members*** — (Not Shown) — Main runners nom 12 ft long, spaced 48 in. OC. Primary cross tees (1-1/2 in. wide across flange) or cross channels, nom 4 ft long, installed perpendicular to main runners and spaced 24 in. OC. Additional primary cross tees or cross channels required at each gypsum board end joint, 8 in. from and on each side of gypsum board end joint, and 8 in. from each side of NEMA Type G (Item 11) light fixtures. Secondary cross tees (15/16 in. wide across flange), nom 4 ft long, installed at sides of NEMA Type G light fixtures. When NEMA Type F (Item 11A) light fixtures are used, nom 4 ft long primary cross tees installed perpendicular to main runners and spaced nom 50 in. OC. Two nom 50 in. long primary cross tees installed perpendicular to nom 4 ft long primary cross tees and spaced nom 14 in. OC to accommodate nom 1 by 2 ft or 1 by 4 ft NEMA Type F fixture or spaced 26 in. OC to accommodate nom 2 by 2 ft or 2 by 4 ft NEMA Type F fixture. When nom 1 by 2 ft or 2 by 2 ft NEMA Type F fixtures are used, nom 14 in. or 26 in. long primary cross tees to be used to form nom 26 in. long modules at the center of the nom 50 in. long primary cross tees. Additional lengths of primary cross tee to be installed at each end of each nominal 50 in. long primary cross tee to create a nominal 14 or 26 in. by 22 or 24 in. module at each end of light fixture module. Ends of these additional lengths of primary cross tee are to engage cross tee routs at end of fixture and are to be riveted to nom 4 ft long cross tee at opposite end. Additional short lengths of primary cross tee to be installed perpendicular to main runners near center of nom 50 in. long cross tee on each side of light fixture. Ends of these additional short lengths of cross tee are to engage rout of main runner at one end and are to be riveted to nom 50 in. long primary cross tee at opposite end. The main runners, cross tees or cross channels may be riveted or screw-attached to the wall angle or channel to facilitate the ceiling installation.

ARMSTRONG WORLD INDUSTRIES INC — Type DFR-8000

6C. **Alternate Steel Framing Members*** — (Not Shown) — As an alternate to Items 6, 6A and 6B. For use with 1/2 in thick gypsum board only. Nom 12 ft long main runners spaced 48 in. OC. Nom 4 ft long cross channels installed perpendicular to main runners and spaced 24 in. OC. Additional cross channels required 8 in. from and on each side of gypsum board end joints, and 8 in. from each side of light fixtures. Nom 4 ft long cross tees installed perpendicular to main runners to support the 4 ft sides of light fixtures. J-shaped metal trim molding installed at perimeter of light fixture to cover and support the exposed gypsum board edges.

ROXUL USA INC. D/B/A ROCKFON — Types 650, 650C, 670, 670C

6D. **Alternate Steel Framing Members*** — (Not Shown) — As an alternate to Items 6, 6A, 6B and 6C. For use in corridors or rooms having a maximum width dimension of 14 ft. Steel framing members consist of grid runners, locking angle wall molding and hanger bars. Locking angle wall molding secured to walls with steel nails or screws spaced max 24 in. OC. Slots of locking angle wall molding parallel with hanger bars to be aligned with tabbed cutouts in bottom edge of hanger bars. Hanger bars spaced max 50 in. OC and suspended with No. 12 AWG steel hanger wires spaced max 48 in. OC. Adjoining lengths of hanger bar to overlap 12 in. and

to be secured together and suspended by a shared hanger wire. A min clearance of 1/4 in. shall be maintained between the ends of the hanger bars and the walls. Grid runners cut-to-length and installed perpendicular to hanger bars and spaced max 24 in. OC with additional grid runners installed 8 in. OC at gypsum board end joints and adjacent to each side of nom 2 by 2 ft or nom 2 by 4 ft NEMA Type F light fixtures (Item 11A). Grid runners parallel with walls to be spaced max 16 in. from wall. Ends of grid runners to rest on and engage slots of locking angle wall molding with a clearance of 3/8 in. to 1/2 in. maintained between each end of the grid runner and the wall. Bulb of grid runner to be captured by tabbed cutouts in bottom edge of hanger bars. When NEMA Type F light fixtures are used, flange of grid runner on each side of fixture module is to be slit and bent upward 90 deg along the length dimension of the fixture. Nom 24 in. long cross tees with tabbed ends bent 90 deg are to be formed from lengths of grid runner and are to be secured to the grid runner at each end of the fixture module using steel screws or rivets. Additional cross tees, nom 8 in. long with tabbed ends bent 90 deg, are to be formed from lengths of grid runner and are to be secured to the grid runners at the corners and center of each side of the fixture module using steel screws or rivets.

ARMSTRONG WORLD INDUSTRIES INC — Type DFR-8000-SS

6E. Alternate Steel Framing Members* — (Not Shown) — As an alternate to Items 6, 6A, 6B, 6C and 6D. Main runners nom 12 ft long, spaced 72 in. OC. Cross tees, nom 6 ft long, installed perpendicular to main runners and spaced 24 in. OC. Additional 6 ft long cross tees required at each gypsum board end joint with butted gypsum board end joints centered between cross tees spaced 8 in. OC. When NEMA Type F (Item 11A) light fixtures are used, nom 6 ft long cross tees installed perpendicular to main runners and spaced nom 14 in., 26 in. or 50 in. OC, dependent upon fixture size and orientation. Nominal 14 in., 26 in. and/or 50 in. cross tees used in combination with the 6 ft long cross tees to create modules to accommodate nom 1 by 2 ft, 1 by 4 ft, 2 by 2 ft and 2 by 4 ft NEMA Type F fixtures. Additional lengths of cross tee to be installed between the 6 ft long cross tees at each end of each nominal 14 in., 26 in. or 50 in. long cross tee forming a light fixture module. Ends of these additional lengths of cross tee are to engage cross tee routs at end of fixture and are to be riveted to nom 6 ft long cross tee at opposite end. Additional short lengths of cross tee to be installed perpendicular to main runners near center of nom 50 in. long cross tee on each side of 1 by 4 ft or 2 by 4 ft light fixture which is installed with its long dimension parallel with the main runners. Ends of these additional short lengths of cross tee are to engage rout of main runner at one end and are to be riveted to nom 50 in. long cross tee at opposite end. The main runners and cross tees may be riveted or screw-attached to the wall angle or channel to facilitate the ceiling installation.

ARMSTRONG WORLD INDUSTRIES INC — Type DFR-8000

6F. Alternate Steel Framing Members* — (Not Shown) — As an alternate to Items 6 through 6E- Main runners nom 12 ft long, spaced 72 in. OC. Cross tees, nom 6 ft long, installed perpendicular to main runners and spaced 24 in. OC. Additional 6 ft long cross tees required at each gypsum board end joint with butted gypsum board end joints centered between cross tees spaced 8 in. OC. When NEMA Type F (Item 11A) light fixtures are used, nom 6 ft long cross tees installed perpendicular to main runners and spaced nom 14 in., 26 in. or 50 in. OC, dependent upon fixture size and orientation. Nominal 14 in., 26 in. and/or 50 in. cross tees used in combination with the 6 ft long cross tees to create modules to accommodate nom 1 by 2 ft, 1 by 4 ft, 2 by 2 ft and 2 by 4 ft NEMA Type F fixtures. Additional lengths of cross tee to be installed between the 6 ft long cross tees at each end of each nominal 14 in., 26 in. or 50 in. long cross tee forming a light fixture module. Ends of these additional lengths of cross tee are to engage cross tee routs at end of fixture and are to be riveted to nom 6 ft long cross tee at opposite end. Additional short lengths of cross tee to be installed perpendicular to main runners near center of nom 50 in. long cross tee on each side of 1 by 4 ft or 2 by 4 ft light fixture which is installed with its long dimension parallel with the main runners. Ends of these additional short lengths of cross tee are to engage rout of main runner at one end and are to be riveted to nom 50 in. long cross tee at opposite end. The main runners and cross tees may be riveted or screw-attached to the wall angle or channel to facilitate the ceiling installation.

USG INTERIORS LLC — Type DGL or RX

6G. Alternate Steel Framing Members* — (Not Shown) — As an alternate to Items 6 through 6F - Main runners nom 12 ft long, spaced 48 in. OC. Cross tees, nom 4 ft. long, installed perpendicular to main runners and spaced 24 in. OC. Additional 4 ft. long cross tees required at 6 in. from each side of butted gypsum board end joints. When Batts and Blankets* (Item 13A) are used, cross tees spaced 16 in. OC with additional cross tees 8 in. away from each side of butted gypsum board end joints. The cross tees shall be riveted with 1/8 in. dia. rivets to the wall angle and to the main tee where the cross tee does not align with slot in the main tee. When NEMA Type F (Item 11A) light fixtures are used, nom 4ft long cross tees, 1-1/2 in wide face, installed perpendicular to main runners and spaced nom 50 in. O.C. Two nom 50 in. long cross tees, 1-1/2 inch wide face, spaced nom 14 in. O.C. to accommodate nom 1 by 2 ft or 1 by 4 ft NEMA Type F fixture or spaced 26 in. O.C. to accommodate nom 2 by 2 ft NEMA or 2 by 4 ft NEMA Type F fixture. When nom 2 by 2 ft NEMA Type F fixture is used, nom 26 in. long cross tees to be used to form nom 26 in. module at the center of the nom 50 in. long cross tees. Two additional nom 4 ft cross tees, 1-1/2 in. wide face are installed perpendicular to the main runners outside each end of fixture opening to support the end pieces of drywall fixture protection. Small cutoff pieces of cross tees are installed at the center of the nom 50 in. long cross tees and main runners by inserting the dip end into a cross tee slot on the main runner and securing the other end with a pop rivet to the nom 50 in. long cross tee. Galvanized steel wall angle with 1-1/2 in.

legs attached to walls at perimeter of ceiling with fasteners at 16 in. OC. to support steel framing member ends and for screw-attachment of the gypsum board.

CERTAINTED CORP — Types DWS12-13-20, DWS4.16-13-20, DWS4-13-20, DWS2-13-20, DWS2.16-13-20 and DWA1.5-1.5

6H. Alternate Framing Members* — (Not Shown) — As an alternate to Items 6 through 6G. Main runners nom 12 ft long, spaced 72 in. OC. Main runners suspended by min 12 SWG galv steel hanger wires spaced 48 in. OC. Cross tees, nom 6 ft long, installed perpendicular to main runners and spaced 24 in. OC. Additional 6 ft long cross tees required at each gypsum board end joint with butted gypsum board end joints centered between cross tees spaced 8 in. OC. The main runners and cross tees may be riveted or screw attached to the wall angle or channel to facilitate the ceiling installation.

ROXUL USA INC. D/B/A ROCKFON — Type 670C

7. Wall Angle — (Not Shown) — No. 26 MSG angle with 1-1/8 in. legs, nailed to the walls along perimeter of ceiling to support steel framing member ends and for screw-attachment of the gypsum board.

8. Cold Rolled Channels — No. 16 MSG cold-rolled steel, 1-1/2 in. deep, spaced approx 24 in. OC.

9. Air Duct — No. 20 MSG galv steel. Total area of duct openings not to exceed 57 sq in. per 100 sq ft of ceiling area. Area of individual duct opening not to exceed 113 sq in. Max dimension of opening is 12 in. Duct supported by cold rolled channels, spaced approx 24 in. OC.

10. Damper — Nom 16 by 16 in. damper, formed from No. 16 MSG galv steel, protected on both surfaces with 1/16 inch thick ceramic fiber paper and held open with Fusible Link (Bearing the UL Listing Mark). Damper to overlap duct outlet a min 1 in.

11. Fixtures, Recessed Light — (Bearing the UL Listing Mark) — Nom 2 by 4 ft recessed light fixture with steel housing. Fixtures spaced so their area does not exceed 24 sq ft per 100 sq ft of ceiling area. Fixture wired in conformance with the National Electric Code. Fixtures and ballasts must be considered for these ambient temperature conditions before installation.

11A. Alternate Fixtures, Recessed Light — For Use with Steel Framing Members, Item 6B, 6D, 6E, 6F, 6G - (Bearing the UL Listing Mark). Recessed light fixture with NEMA Type F steel housing, 1 by 2 ft, 1 by 4 ft, 2 by 2 ft or 2 by 4 ft size. Fixtures provided with swing-out steel support hooks near each corner designed to engage the bulb of the steel framing member cross tees. Size of steel framing member module to be nominally 2 in. wider and longer than the nominal fixture size. Fixtures to be additionally screw-attached to the web of the cross tees near the center of each long side and at both ends using No. 6 by 2-5/8 in. long (sides) and No. 6 by 1-5/8 in. long (ends) steel drywall screws. Fixtures spaced so their area does not exceed 24 sq ft per each 100 sq ft of ceiling area. Wired in conformance with the National Electrical Code.

11B. Alternate Fixtures, Recessed Light — For Use with Steel Framing Members, Item 6- (Bearing the UL Listing Mark). Recessed light fixture with NEMA Type F steel housing, 1 by 2 ft, 1 by 4 ft, 2 by 2 ft or 2 by 4 ft size. Fixtures provided with swing-out steel support hooks near each corner designed to engage the bulb of the steel framing member cross tees. Fixtures to be additionally screw-attached to the cross tees near the center of each long side and at both ends using 2 in. long Type S-12 (sides) and 3 in. long Type S-12 (ends) steel screws. Fixtures spaced so their area does not exceed 24 sq ft per each 100 sq ft of ceiling area. Wired in conformance with the National Electrical Code.

12. Fixture Protection — Gypsum Board* — Nom 1/2 or 5/8 in. thick gypsum board, same as Item 14, 14A or 14B. Sheets cut into pieces to form a five sided enclosure for fixture (Item 11), trapezoidal in cross section, approx 1/2 in. longer and wider than the fixture with sufficient depth to provide at least 1/2 in. clearance between the fixture and enclosure.

12A. Fixture Protection — Gypsum Board* — For Use with Steel Framing Members, Item 6B, 6D, 6E, 6F, 6G - 5/8 in. thick, same as Item 14, 14A, 14B, or 14C. Cut to form a five-sided enclosure, rectangular in cross-section, at least 1-1/4 in. higher than the NEMA Type F light fixture housing (Item 11A). The fixture protection enclosure is to be installed in the grid module prior to installation of the NEMA Type F light fixture. The fixture protection side pieces are to be provided with nominal 1-1/4 in. wide by 3-1/2 in. long cutouts to accommodate the swing-out steel support hooks near each corner of the fixture. The fixture protection side and end pieces rest on the flanges of the primary cross tees and are screw-attached to the web of the cross tee with No. 6 by 1-5/8 in. long steel drywall screws. The top piece rests on the top edges of the side and end pieces without mechanical attachment. The dimensions of the fixture protection pieces for the various sizes of NEMA Type F fixtures are tabulated below:

NEMA Type F Fixture Size	1 by 2 ft	1 by 4 ft	2 by 2 ft	2 by 4 ft
Top Piece, in.	13-1/2 x 25-1/2	13-1/2 x 49-1/2	25-1/2 x 25-1/2	25-1/2 x 49-1/2
Side Piece, in.	7 x 25-1/2	7 x 49-1/2	7 x 25-1/2	7 x 49-1/2
End Piece, in.	7 x 12-1/4	7 x 12-1/4	7 x 24-1/4	7 x 24-1/4

12B. Fixture Protection — Gypsum Board* — For Use with Steel Framing Members, Item 6 - 1/2 or 5/8 in. thick, same as Item 14, 14A or 14B. Cut to form a five-sided enclosure, rectangular in cross section, for the NEMA Type F light fixture (Item 11B). The fixture protection enclosure is installed around the grid module prior to installation of the NEMA Type F light fixture. The end pieces of the light fixture protection rest upon the flanges additional nom 4 ft long cross tees placed at each end of light fixture opening. The pieces of gypsum board are secured to both cross tees with three 1 in. long Type S screws, one at the center of the cross tee and the remaining two screws spaced 12 in. O.C. in both directions. The end clips of the two additional cross tees are removed and the cross tee/gypsum board combinations are placed at each end of the module facing the light fixture opening with the ends of the cross tees resting on the flanges of the main runner. Two side pieces of the gypsum board protection are notched at the bottom with three 1/4 in. wide by 1-9/16 in. long notches to accommodate the cross-tee bulbs. On each side the pieces are installed vertically, resting on the three cross tees intersecting the 50 in. long cross tees and placed 1-1/4 in from the edge of the 50 in. cross tees. The four side pieces of the light fixture protection box are secured together with 6d nails, one at mid-height, and one at each of the four corners. The top piece of gypsum board is loosely-laid on top of the four-sided box and secured at each of the four corners with 6d nails. Holes are drilled through the top piece of gypsum board for the attachment of the hanger wires specified in Item 5. Two 4 ft long cross-tees are placed on top of the fixture protection box, equally spaced and secured from the underside of the fixture protection box with three 1 in. long Type S screws equally spaced. The dimensions of the fixture protection pieces for the various sizes of NEMA Type F fixtures are listed below:

NEMA Type F Fixture Size	1 by 2 ft	1 by 4 ft	2 by 2 ft	2 by 4 ft
Top piece, in.	19 x 31	19 x 55	31 x 31	31 x 55
Side pieces, in	6 x 30	6 x 54	6 x 30	6 x 54
End pieces, in	6 x 19	6 x 19	6 x 31	6 x 31

13. Batts and Blankets* — (Optional, Not Shown) — For use with **Steel Framing Members*** (specifically Item 6) and **Gypsum Board*** (specifically Item 14B) - Any thickness mineral wool or glass fiber insulation bearing the UL Classification Marking for Surface Burning Characteristics, having a flame spread value of 25 or less and a smoke spread value of 50 or less. Insulation fitted in the concealed space, draped over steel framing members/gypsum wallboard ceiling membrane.

13A. Batts and Blankets* — (Optional, Not Shown) — For use with **Steel Framing Members*** (specifically Item 6G) and **Gypsum Board*** (specifically Item 14C) - min. 3-1/2 in. thick, min. density 0.9 lb/ft³ unfaced fiberglass batt insulation bearing the UL Classification Marking for Surface Burning Characteristics, having a flame spread value of 25 or less and a smoke spread value of 50 or less. Insulation fitted in the concealed space, draped over steel framing members/gypsum board ceiling membrane and light fixture protection.

14. Gypsum Board* — (For use with **Steel Framing Members*** described in Items 6 and 6B) — Nom 1/2 and 5/8 in. thick, 4 ft wide gypsum board, installed with long dimension perpendicular to cross channels with side joints centered along main runners. Gypsum board fastened to cross channels with 1 in. long No. 8 Type S-12 bugle head screws located 1/2 in. from end joints and 1-3/4 in. from each side joint and spaced 12 in. OC along the end joints and in the field. End joints of adjacent gypsum board sheets shall be staggered not less than 4 ft OC. Gypsum board sheets screw-attached to leg of wall angle with drywall screws spaced 12 in. OC. When alternate **Steel Framing Members*** (Item 6C) are used, gypsum board installed with long dimension (side joints) perpendicular to the cross channels and 4 ft cross tees, and with the side joints centered along the main runners. Gypsum board fastened to cross channels with five 1 in. long No. 8 Type S-12 bugle head screws located 1/2 in. from butted end joints, with one screw located at the midspan of the cross channel, one screw located 12 in. from and on each side of the channel midspan, and one screw located 2-3/4 in. from each side joint. End joints of the sheets shall be staggered as described above.

When alternate **Steel Framing Members*** (Item 6D) are used, gypsum board sheets installed with long dimension (side joints) perpendicular to the grid runners with the end joints staggered min 4 ft and centered between grid runners which are spaced 8 in. OC. Prior to installation of the gypsum board sheets, backer strips consisting of nom 7-3/4 in. wide by 48 in. long pieces of gypsum board are to be laid atop the grid runner flanges and centered over each butted end joint location. The backer strips are to be secured to the flanges of the grid runners at opposite corners of the backer strip to prevent the backer strips from being uplifted during screw-attachment of the gypsum board sheets. Gypsum board fastened to grid runners with drywall screws spaced 1 in. and 4 in. from the side joints and max 8 in. OC in the field of the board. The butted end joints are to be secured to the backer strip with No. 10 by 1-1/2 in. long Type G laminating screws located 1 in. from each side of the butted end joint and spaced 1 in. and 4 in. from the side joints and max 8 in. OC in the field of the board.

When alternate **Steel Framing Members*** (Item 6E) are used, gypsum board sheets installed with long dimension (side joints) perpendicular to the 6 ft long cross tees with the end joints staggered min 4 ft and centered between cross tees which are spaced 8 in. OC. Gypsum board side joints may occur beneath or between main runners. Prior to installation of the gypsum board sheets, backer strips consisting of nom 7-3/4 in. wide pieces of gypsum board are to be laid atop the cross tee flanges and centered over each butted end joint location. The backer strips are to be secured to the flanges of the cross tees at opposite corners of the backer strip to prevent the backer strips from being uplifted during screw-attachment of the gypsum board sheets. Gypsum board fastened to cross tees with drywall screws spaced 1 in. and 4 in. from the side joints and max 8 in. OC in the field of the board. The butted end joints are to be secured to the backer strip with No. 10 by 1-1/2 in. long Type G laminating screws located 1 in. from each side of the butted end joint and spaced 1 in. and 4 in. from the side joints and max 8 in. OC in the field of the board.

When alternate **Steel Framing Members*** (Item 6F and 6H) are used, gypsum board sheets installed with long dimension (side joints) perpendicular to the 6 ft long cross tees with the end joints staggered min 4 ft and centered between cross tees which are spaced 8 in. OC. Gypsum board side joints may occur beneath or between main runners. Prior to installation of the gypsum board sheets, backer strips consisting of nom 7-3/4 in. wide pieces of gypsum board are to be laid atop the cross tee flanges and centered over each butted end joint location. The backer strips are to be secured to the flanges of the cross tees at opposite corners of the backer strip with hold down clips to prevent the backer strips from being uplifted during screw-attachment of the gypsum board sheets. Gypsum board fastened to cross tees with 1 in. drywall screws spaced 1 in. and 4 in. from the side joints and max 8 in. OC in the field of the board. The butted end joints are to be secured to the backer strip with No. 10 by 1-1/2 in. long Type G laminating screws located 1 in. from each side of the butted end joint and spaced 1 in. and 4 in. from the side joints and max 8 in. OC in the field of the board.

AMERICAN GYPSUM CO — Type AG-C

CABOT MANUFACTURING ULC — Type C

CERTAINTED GYPSUM INC — Type C

CGC INC — Type C, IP-X2

CERTAINTED GYPSUM INC — Type LGFC-C/A

GEORGIA-PACIFIC GYPSUM L L C — Types 5, DAPC, TG-C

NATIONAL GYPSUM CO — Types eXP-C, FSK-C, FSW-C

PABCO BUILDING PRODUCTS L L C, DBA PABCO GYPSUM — Types C, PG-C

PANEL REY S A — Types PRC, PRC2

THAI GYPSUM PRODUCTS PCL — Type C

UNITED STATES GYPSUM CO — Type C

USG BORAL DRYWALL SFZ LLC — Type C

USG MEXICO S A DE C V — Type C

14A. **Gypsum Board*** — (For use with **Steel Framing Member*** described in Item 6A) - Nom 1/2 and 5/8 in. thick, 4 ft wide gypsum board, installed with long dimension perpendicular to cross tees with side joints centered along main runners. Gypsum board fastened to each cross tee with five 1 in. long No. 8 Type S-12 bugle head screws with one screw located at the midspan of the cross tee, one screw located 12 in. from and on each side of the cross tee midspan, and one screw located 1-1/2 in. from each gypsum board side joint. Except at gypsum board end joints, screws shall be located on alternating sides of cross tee flange. At gypsum board end joints, screws shall be located 1/2 in. from the joint. Gypsum board fastened to main runners with 1 in. long No. 8 Type S-12 bugle head screws, 1/2 in. from side joints, midway between intersections with cross tees (24 in. OC). End joints of adjacent gypsum board sheets shall be staggered not less than 4 ft OC. Gypsum board also screw attached to leg of wall angle with 1 in. long No. 8 Type S bugle head screws spaced 12 in. OC.

AMERICAN GYPSUM CO — Type AG-C

CERTAINTED GYPSUM INC — Type C

CGC INC — Type C, IP-X2

CERTAINTED GYPSUM INC — Type LGFC-C/A

GEORGIA-PACIFIC GYPSUM L L C — Types 5, DAPC, TG-C

NATIONAL GYPSUM CO — Types eXP-C, FSK-C, FSW-C

PABCO BUILDING PRODUCTS L L C, DBA PABCO GYPSUM — Types C, PG-C

PANEL REY S A — Types PRC, PRC2

THAI GYPSUM PRODUCTS PCL — Type C

UNITED STATES GYPSUM CO — Type C

USG BORAL DRYWALL SFZ LLC — Type C

USG MEXICO S A DE C V — Type C

14B. **Gypsum Board*** — (For use with **Batts and Blankets*** and **Steel Framing Members*** described in Items 13 and 6, respectively) — Nom 5/8 in. thick, 4 ft wide gypsum board, installed with long dimension perpendicular to cross tees with side joints centered along main runners and end joints centered along cross tees. Gypsum board fastened to cross tees with 1 in. long No. 8 Type S-12 bugle head screws spaced 8 in. OC in the field and 8 in. OC along end joints. Gypsum board fastened to main runners with 1 in. long No. 8 Type S-12 bugle head screws spaced midway between cross tees. Screws along sides and ends of boards spaced 3/8 to 1/2 in. from board edge. End joints shall be staggered with spacing between joints on adjacent boards not less than 4 ft OC.

CGC INC — Type C

UNITED STATES GYPSUM CO — Type C

USG BORAL DRYWALL SFZ LLC — Type C

USG MEXICO S A DE C V — Type C

14C. **Gypsum Board*** — For use when alternate **Steel Framing Members*** (Item 6G) are used - 1/2 in. thick, 4 ft. wide; installed with long dimension parallel to main runners and perpendicular to the 4 ft. long cross tees with the end joints centered between cross tees which are spaced 6 in. OC. Sheets are attached to cross tees with screws spaced 8 in. OC on the ends and 12 in. OC in the field with additional screws located 1-1/2 in. from the side edges. Sheets are attached to the main tees with screws spaced 8 in. OC with additional screws located 4 in. OC from the edges. Screws on the sides are located 1/2 in. from the side edge of the gypsum board. When **Batts and Blankets*** (Item 13A) are used - 5/8 in. thick, 4 ft wide; installed with long dimension parallel to main runners and perpendicular to cross tees and attached with screws spaced 8 in. OC on the ends and 8 in. OC in the field with additional screws located 1-1/2 in. from the side edges. Sheets are attached to main tees with screws spaced 8 in. OC with additional screws located 4 in. OC from the side edges. Screws on the sides located 3/4 in. from the side edge of the gypsum board, and screws at the end of the gypsum board located 1/2 in. from the board ends. Joints to be covered with paper tape and joint compound.

CERTAINTED GYPSUM INC — Type C

14D. **Gypsum Board* (As an alternative to Items 14, 14A and 14B)** — Nom 5/8 in. thick, 48 in. wide gypsum board, installed and secured as described in Items 14, 14A and 14B with max screw spacing 8 in. OC.

CGC INC — Type ULIX

UNITED STATES GYPSUM CO — ULIX

15. **Metal Trim Molding** — No. 22 MSG molding channel, measuring 5/8 in. wide with 9/16 and 1-3/8 in. long legs. Placed on gypsum board edges around light fixtures and secured to the cross tees and main runners with 1 in. long No. 8 Type S bugle head screws. Spacing of screws approx 8 in. OC along 4 ft side and 10 in. OC along 2 ft side of light fixtures.

16. **Finishing System** — (Not Shown) — Vinyl, dry or premixed joint compound, applied in two coats to joints and screw-heads. Nom 2 in. wide paper tape embedded in first layer of compound over all joints. As an alternate, nom 3/32 in. thick veneer plaster may be applied to the entire surface of gypsum board.

*** Indicates such products shall bear the UL or cUL Certification Mark for jurisdictions employing the UL or cUL Certification (such as Canada), respectively.**

Last Updated on 2021-09-06

La presencia del nombre de una empresa o producto en esta base de datos no garantiza por sí misma que los productos así identificados hayan sido fabricados bajo el servicio de seguimiento de UL. Solo aquellos productos que lleven la marca UL deben considerarse como certificados y garantizados bajo el servicio de seguimiento de UL. Busque siempre la marca en el producto.

UL permite la reproducción del material contenido en el directorio de certificación en línea sujeta a las siguientes condiciones: 1. La información de la guía, las ensamblajes, las construcciones, los diseños, los sistemas y/o certificaciones (archivos) deben presentarse en su totalidad y de forma no engañosa, sin ninguna manipulación en los datos (o dibujos). 2. Debe aparecer la declaración "Reimpreso desde el directorio de certificaciones en línea con permiso de UL" junto al material extraído. Además, el material reimpreso debe incluir una nota de derechos de autor en el siguiente formato: "© 2021 UL LLC"