

BXUV.D301 - Fire-resistance Ratings - ANSI/UL 263



Design/System/Construction/Assembly Usage Disclaimer

- Authorities Having Jurisdiction should be consulted in all cases as to the particular requirements covering the installation and use of UL Certified products, equipment, system, devices, and materials.
- Authorities Having Jurisdiction should be consulted before construction.
- Fire resistance assemblies and products are developed by the design submitter and have been investigated by UL for compliance with applicable requirements. The published information cannot always address every construction nuance encountered in the field.
- When field issues arise, it is recommended the first contact for assistance be the technical service staff provided by the product manufacturer noted for the design. Users of fire resistance assemblies are advised to consult the general Guide Information for each product category and each group of assemblies. The Guide Information includes specifics concerning alternate materials and alternate methods of construction.
- Only products which bear UL's Mark are considered Certified.

BXUV - Fire Resistance Ratings - ANSI/UL 263 Certified for United States

BXUV7 - Fire Resistance Ratings - CAN/ULC-S101 Certified for Canada

[See General Information for Fire-resistance Ratings - ANSI/UL 263 Certified for United States Design Criteria and Allowable Variances](#)

[See General Information for Fire Resistance Ratings - CAN/ULC-S101 Certified for Canada Design Criteria and Allowable Variances](#)

Design No. D301

February 04, 2021

Restrained Assembly Rating -2 Hr (See Item 10A), 3 Hr.

Unrestrained Assembly Rating - 2 Hr (See Item 10A), 3 Hr.

Unrestrained Beam Rating - 2 Hr (See Item 10A), 4 Hr.

This design was evaluated using a load design method other than the Limit States Design Method (e.g., Working Stress Design Method). For jurisdictions employing the Limit States Design Method, such as Canada, a load restriction factor shall be used – See Guide [BXUV](#) or [BXUV7](#)

*** Indicates such products shall bear the UL or cUL Certification Mark for jurisdictions employing the UL or cUL Certification (such as Canada), respectively.**

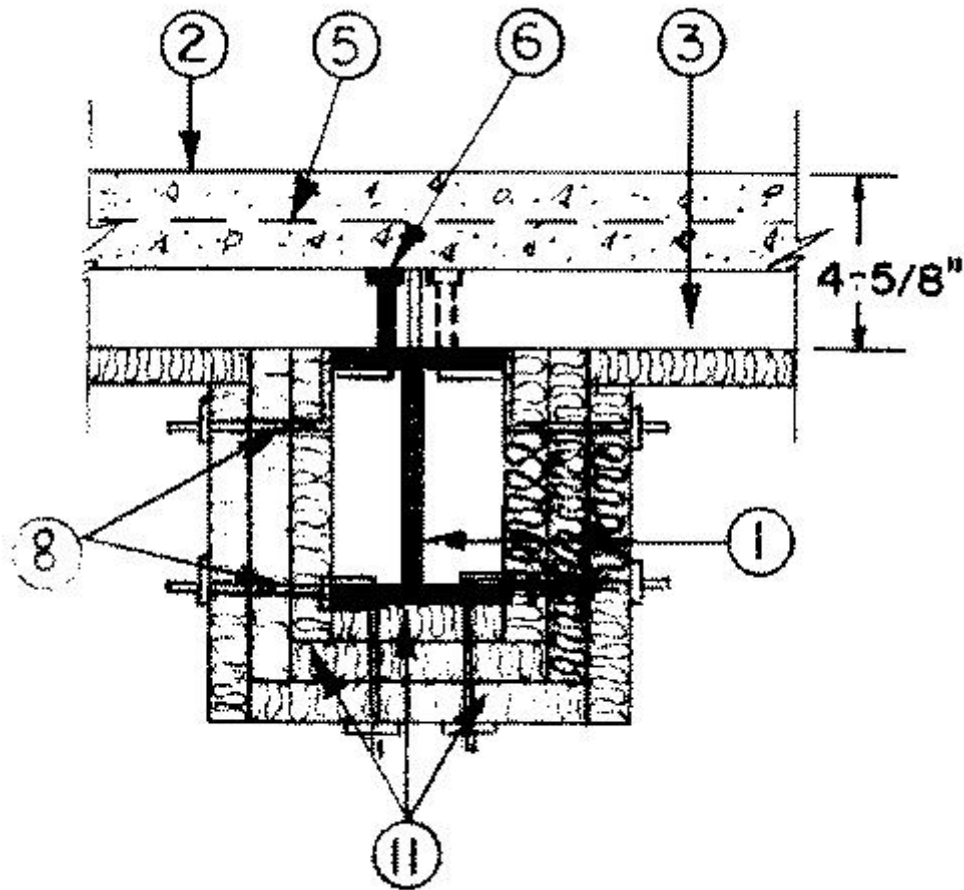
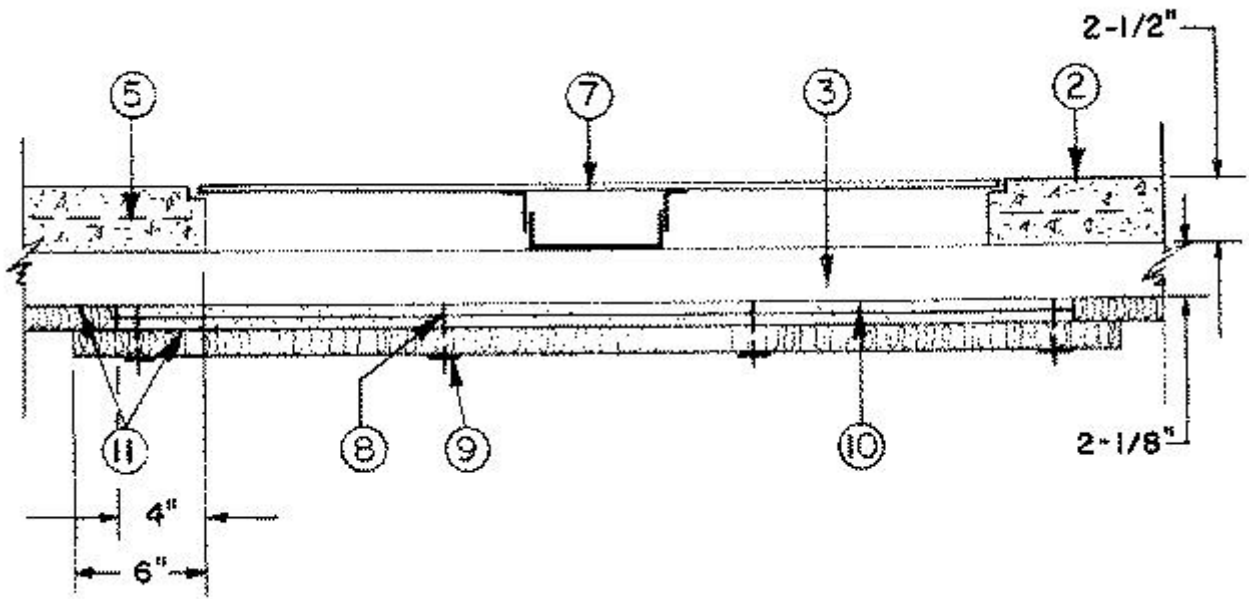

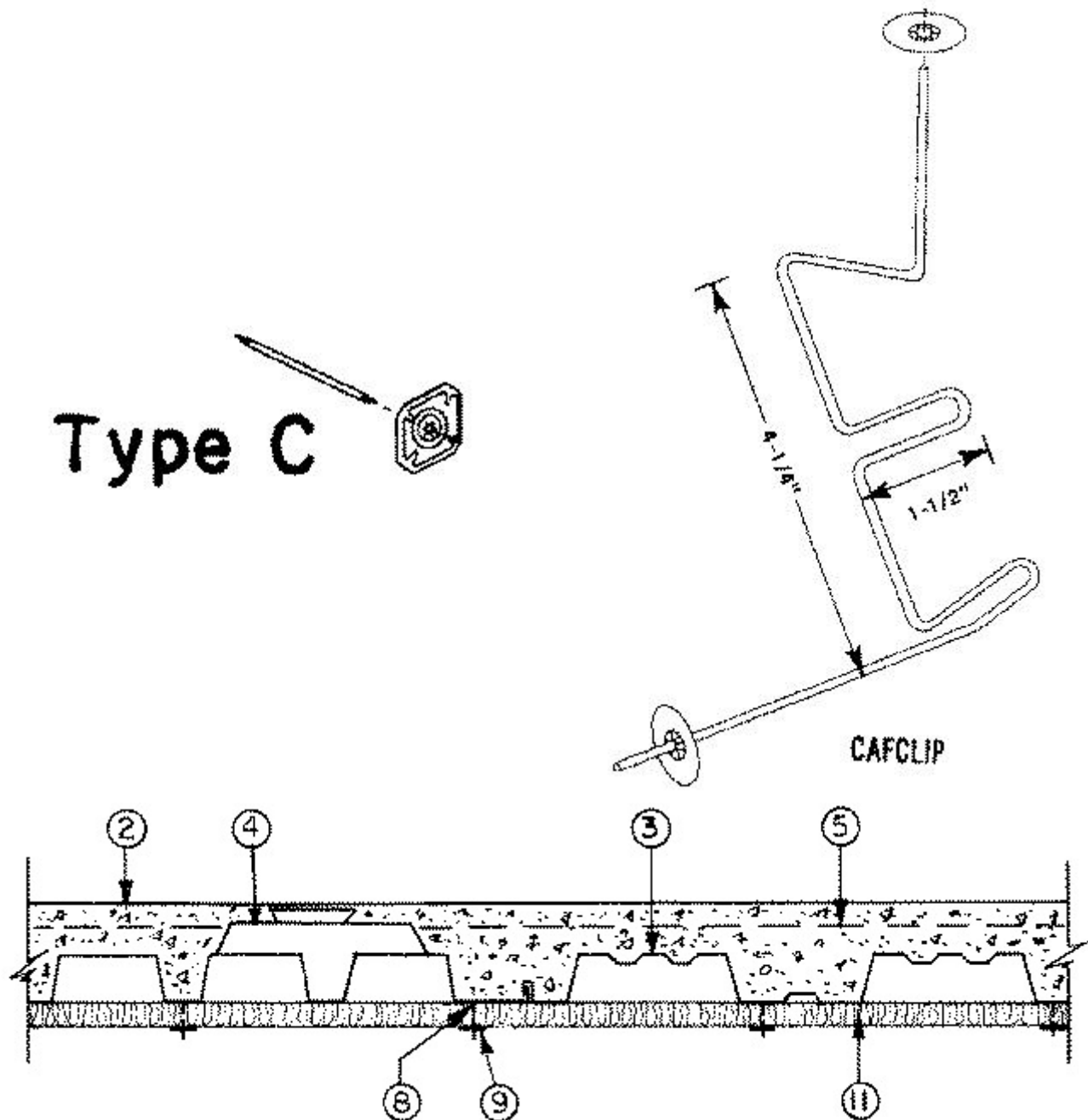

1. **Beam** — W6X12, min size.

2. **Normal — Weight Concrete** — Carbonate or siliceous aggregate, 146 plus or minus 3 pcf unit weight, 3500 psi compressive strength.

3. **Steel Floor And Form Units*** — Composite, nom 2 or 3 in. deep galv fluted and/or cellular units. Min gauges are No. 20 MSG for fluted and No. 20/20 MSG for cellular.

CANAM GROUP INC — 36 in. wide Type P-3623 and 24 in wide Type P-2432 composite.

CANAM STEEL CORP — 36 in. wide Type P-3623 and 24 in wide Type P-2432 composite.

KAM INDUSTRIES LTD, DBA CORDECK — Hi-Bond Types 24 in. wide 3KA1F24; 30 in. wide 3KF30, 3P30.

4. **Electrical Inserts** — (Not shown) — Classified as "**Outlet Boxes and Fittings Classified for Fire Resistance**" * The NRG Bloc IV preset insert is furnished by **KAM INDUSTRIES LTD d/b/a CORDECK**. The service fitting components are furnished by **WIREMOLD CO**. Installed per accompanying installation instructions over factory-punched holes in 3 in. deep K-Type cellular floor units (furnished by **KAM INDUSTRIES LTD d/b/a CORDECK**). The spacing of the preset electrical inserts shall be not less than 24 in. O.C. along cellular steel floor units with not more than one preset electrical insert in each 4 sq ft of floor area. Either Type RAKM-II, FAKM-II, S36BB, S36CC, S36PB, S36PP, S38CC, S38BB, S38PB, S38PP, FPCTC, FPBTC, FPFFTC service fittings or Type S3AXBP abandonment plate are installed with Type N-R-G Bloc IV Series preset inserts per accompanying installation instructions. Refer to installation instructions for Classified assemblies.

WIREMOLD CO — Type N-R-G Bloc IV Series inserts; Type RAKM-II, FAKM-II, S36BB, S36CC, S36PB, S36PP, S38CC, S38BB, S38PB, S38PP, FPCTC, FPBTC, FPFFTC service fittings or Type S3AXBP abandonment plate.

5. **Welded Wire Fabric** — 6 X 6 W1.4 X W1.4.

6. **Shear Connectors** — (**Optional**) — Studs, 3/4 in. diam by 4 in. long, headed type or equivalent per AISC specifications. Welded to top flange of beam through the deck.

7. **Trench Header** — Trench header (Bearing the UL Listing Mark), without the bottom pan. The allowable superimposed load for spans with bottomless trench header shall be based on noncomposite design. This trench header, ranging in width from min 12 in. to max 36 in., consists of two cell closers which conform to the contour of the floor units, placed along the sides of the desired trench location and welded to the floor units. The side rails, consisting of extruded aluminum screeds secured to galv steel channels (min No. 18 MSG) are positioned over the cell closers, aligned and welded to the closers and floor units. A separate U-shaped galvanized steel channel (min No. 18 gauge) serving as the power compartment, is welded to the floor units. Steel cover plates, 1/4 in. thick shall be secured to the side rails. In bottomless trench headers wider than 18 in., each side joint of the steel floor units shall be welded together with a 1 in. long weld near the trench header centerline. The use of this trench requires additional protection underneath the trench, one layer of batts backed by two layers of Gypsum Board, (Item 10).

8. **Fasteners** — Cafclip No. 11 SWG, used on beams only, spaced lengthwise not greater than 12 in. O.C. and 2-1/4 in. from ends of batts. Type C, No. 10 SWG copper coated steel wire studs of different lengths welded to valleys and flat plates of steel floor units in the general floor area and below trench header. Type C studs spaced a max of 14 in. OC along the sides and a max of 9 in. along the ends of the batts, at 3 in. from edges of batts. Min. 1/2 in. fastener excess, bent or cut. As an alternate detail, spacing for edge fasteners, across joint, not to exceed 12 in. O.C. when tie wire secured behind the clinch shields and spanned twice across joint.

9. **Clinch Shield** — No. 26 MSG galv steel 1-1/2 in. diam round clinch shields for use with Cafclip. Round or square clinch shields 1 in. sq. min for use with Type C steel wire studs.

10. **Gypsum Board*** — Two layers of 5/8 in. thick, 4 ft wide by 10 ft long. Sheets impaled over wire fasteners welded to steel deck beneath the trench header, and extending a min of 4 in. beyond both sides of the trench header. End joints between the two layers shall be staggered.

AMERICAN GYPSUM CO — Type AG-C

CERTAINTED GYPSUM INC — Type C, Type LGFC-C/A.

CGC INC — Types C, IP-X2

GEORGIA-PACIFIC GYPSUM L L C — Types 5, DAPC, Type TG-C.

PABCO BUILDING PRODUCTS L L C, DBA PABCO GYPSUM — Type C.

PANEL REY S A — Type PRC

THAI GYPSUM PRODUCTS PCL — Type C

UNITED STATES GYPSUM CO — Types C, IP-X2

USG BORAL DRYWALL SFZ LLC — Type C

USG MEXICO S A DE C V — Types C, IP-X2.

10A. Gypsum Board* (As an alternative to Item 10, rating is limited to 2 Hr) — Two layers of 5/8 in. thick, 4 ft wide by 10 ft long. Sheets impaled over wire fasteners welded to steel deck beneath the trench header, and extending a min of 4 in. beyond both sides of the trench header. End joints between the two layers shall be staggered.

CGC INC — ULIX

UNITED STATES GYPSUM CO — ULIX

11. Batts and Blankets* — Mineral wool batts, 24 by 48 by 1 in. thick. Attached to beam (three layers) and steel deck (one layer) by impaling over wire fasteners. Joints spaced 48 in. OC and staggered a min of 1 in. between layers of batts on beam. Batts under trench header to extend 2 in. beyond both sides of the gypsum wallboard backing. The 1 in. thick mineral wool batts may have an optional foil facing for the exposed surface only.

UNITED STATES MINERAL PRODUCTS CO, DBA ISOLATEK INTERNATIONAL — Type CB.

*** Indicates such products shall bear the UL or cUL Certification Mark for jurisdictions employing the UL or cUL Certification (such as Canada), respectively.**

Last Updated on 2021-02-04

La presencia del nombre de una empresa o producto en esta base de datos no garantiza por sí misma que los productos así identificados hayan sido fabricados bajo el servicio de seguimiento de UL. Solo aquellos productos que lleven la marca UL deben considerarse como certificados y garantizados bajo el servicio de seguimiento de UL. Busque siempre la marca en el producto.

UL permite la reproducción del material contenido en el directorio de certificación en línea sujeta a las siguientes condiciones: 1. La información de la guía, las ensamblajes, las construcciones, los diseños, los sistemas y/o certificaciones (archivos) deben presentarse en su totalidad y de forma no engañosa, sin ninguna manipulación en los datos (o dibujos). 2. Debe aparecer la declaración "Reimpreso desde el directorio de certificaciones en línea con permiso de UL" junto al material extraído. Además, el material reimpreso debe incluir una nota de derechos de autor en el siguiente formato: "© 2021 UL LLC"